

5-C EXPANDING COLLETS
SERIES 326:



EAGLE ROCK



MEDA
Superior Import

5-C EXPANDING COLLET SETS

4 Piece Set allows "internal chucking" within the range .250" through 1.937". Heads are machinable. Shanks are precision ground to maintain concentricity with ±.0005".

Size	Range	MEDA		EAGLE ROCK	
		Order No.	Price	Order No.	Price
1	.250 - .468	1980001		3260121	
2	.437 - .800	1980002		3260110	
3	.750 - 1.437	1980003		3260112	
4	.750 - 1.937	1980004		3261201	
Complete set of 4 on a wooden rack.					
1-4	.250 - 1.937	1980005		3260005	

The most effective and accurate means of internal chucking for short runs to mass production. Once seated in spindle and machined to size, these collets can hold concentricity well within .0005". Applicable on any manual or CNC Lathe, Milling Machine or Grinder with a 5C spindle. Machinable to any configuration within their stock and minimum machinable diameters. Collets with diameters 4" and larger have a lock ring for greater stability and accuracy while machining to their specific application.

EAGLE ROCK

Dia.	Lgth.	Min. Mach. Dia.	Order No.	Price
1/2"	1"	.250"	3260121	
1/2"	*2"	.250"	3260122	
1/2"	*3"	.250"	3260123	
1"	1"	.437"	3260110	
1"	*2"	.437"	3260120	
1"	*3"	.437"	3260130	
1-1/2"	1"	.750"	3260112	
1-1/2"	1-1/2"	.750"	3261121	
1-1/2"	2"	.750"	3261122	
1-1/2"	2-1/2"	.750"	3261212	
1-1/2"	3"	.750"	3261123	
2"	1"	.750"	3261201	
2"	1-1/2"	.750"	3262212	
2"	2"	.750"	3262203	
2"	2-1/2"	.750"	3262221	
2"	3"	.750"	3262230	
2-1/2"	1"	.750"	3262121	
2-1/2"	1-1/2"	.750"	3262122	
2-1/2"	2"	.750"	3262120	
2-1/2"	2-1/2"	.750"	3262222	
2-1/2"	3"	.750"	3262123	
3"	1"	.750"	3263010	
3"	1-1/2"	.750"	3263015	
3"	2"	.750"	3263020	
3"	2-1/2"	.750"	3263025	
3"	3"	.750"	3263030	
4"	1"	.750"	3264010	
4"	1-1/2"	.750"	3264012	
4"	2"	.750"	3264020	
4"	2-1/2"	.750"	3264212	
4"	3"	.750"	3264030	
5"	2"	.750"	3265020	
6"	2"	.750"	3266020	

* Extended 5C Expanding Collets - Made for holding delicate or long and narrow parts or where there is a machine clearance problem. Machinable to any dimension within their range, only the front (1" long) expands.

3-JAW SELF-CENTERING UNIVERSAL LATHE CHUCKS
SERIES 995:

MEDA
Superior Import

Reversible 2 piece jaws except where noted



Plain Back

Chuck Dia.	Thru Hole	Order No.	Price
3"	.630"	2670003	
4"	.866"	2670004	
5"	1.181"	2670005	
6"	1.575"	2670006	
8"	2.559"	2670008	
10"	3.150"	2670010	
12"	3.937"	2670012	

* 2 sets of solid jaws.



D-1 Type Mount

Chuck Dia.	Spindle	Thru Hole	Order No.	Price
6"	D1-4	1.575"	2670604	
8"	D1-4	1.969"	9670804	
8"	D1-6	1.969"	2670806	
10"	D1-6	2.756"	2671006	
12"	D1-6	3.937"	2671206	
12"	D1-8	3.937"	2671208	

3-JAW SELF CENTERING THREADED BACK UNIVERSAL CHUCKS

MEDA
Superior Import

SERIES 995:

5" & 6" x 1-1/2 - 8



5" or 6" Diameter 3-Jaw Universal Lathe Chuck, Plain Back. 2 sets of hardened and ground jaws for inside and outside holding. Chuck Key. High quality cast iron body.

Plus 5" or 6" x 1-1/2"-8 Back Plate made for the chuck (Chuck can be used by itself or with included back plate.)

5" Order No.: 2670512 Price:

6" Order No.: 2670612 Price:

UNIVERSAL THREE-JAW SELF-CENTERING SCROLL CHUCKS

SERIES 267:

These Bison modern, precision lathe chucks can be used on all types of lathes and different kinds of milling, drilling, CNC attachments. Chucks are provided with **American Standard Two-Piece Tongue & Groove Jaws** or with two sets of hard solid OD & ID jaws.

BODY - is made of high quality cast iron. All guideways and bearing surfaces are precisely machined.

SCROLL PLATE - drop forged of fine alloy steel, carefully case hardened. Thread flanks ground on both sides.

JAWS - the teeth and guides are hardened and fully ground on both sides.

PINIONS - hardened and ground.

Two-Piece Jaw Chuck Standard Accessories:

1 set of two-piece reversible jaws (hard top jaws and hard master jaws), 1 self - ejecting wrench, 1 set of mounting screws, 2 allen keys.

Optional Accessories: Soft top jaws.

Solid Jaw Chuck Standard Accessories:

2 sets of hard solid jaws (inside and outside), 1 self - ejecting wrench, mounting bolts, 1 hex key.

Optional Accessories: Soft solid jaws.



Solid Jaw 3" to 25"



Two-Piece Jaw 5" to 25"



Spare parts see pages 548.
Adapter plates see page 557-558.

Chuck Grease
Order No. 7799025
Price:

PLAIN BACK

Chuck Dia.	Hole Dia.	RPM max.	2-pc. Jaws (3205)			Solid Jaws (3204)		
			Wt. lbs.	Order No.	Price	Wt. lbs.	Order No.	Price
3"	.6299	4000	-	-		3.1	78100300	
4"	.7874	3500	-	-		5.3	78100400	
5"	1.2598	3200	10.0	8000500		9.3	78100500	
6-1/4"	1.6535	3000	19.0	8000600		17.0	78100600	
8"	2.1654	2500	34.0	8000800		32.0	78100800	
10"	2.9921	2000	57.0	8001000		52.0	78101000	
12-1/2"	4.0551	1500	96.0	9001200		87.0	78101200	
15-3/4"	5.3543	1000	176	8001600		163	78101600	
20"	7.4803	700	295	8002000		271	78102000	
25"	9.9212	500	529	8002500		469	78102500	
32"*	10.5	300	740	8003200		-		

Note: Plain back chucks require adapter plates which may require machining to fit.



Back View



* 32" Chuck - for more information see page 508.

A-1/A-2 Type Mount (3215)

Chuck Dia.	Taper Size	Hole Dia.	RPM max.	Weight lbs.	Order No.	Price
6-1/4"	A1-5	1.653	3000	22	8010615	
8"	A1-5	1.653	2500	42	8010815	
	A1-6	2.165	2500	42	8010816	
10"	A2-5	2.992	2000	71	8011015	
	A1-6	2.165	2000	71	8011016	
	A1-8	2.992	2000	71	8011018	
12-1/2"	A2-6	4.055	1500	121	8011226	
	A1-8	3.150	1500	121	8011218	
15-3/4"	A2-6	4.055	1000	203	8011616	
	A2-8	5.354	1000	203	8011618	
	A1-11	5.118	1000	203	8011619	
20"	A2-11	7.590	700	353	8012029	
25"	A2-11	7.590	500	628	8012511	
	A2-15	7.590	500	628	8012515	
32"	A2-20	12.598	300	847	8013220	



See page 551 for accuracy and runout specifications.

(Continued)

UNIVERSAL
THREE-JAW
SELF-CENTERING
SCROLL CHUCKS
SERIES 267:



D-1 Type Mount (3245)

Chuck Dia.	Taper Size	Stud Dia.	Hole Dia.	RPM max.	Weight lbs.	Order No.	Price
5"	D1-3	9/16	1.260	3200	11	8030533	
	D1-4	5/8	1.260	3000	11	8030534	
6-1/4"	D1-3	9/16	1.654	3000	20	8030633	
	D1-4	5/8	1.654	3000	20	8030634	
8"	D1-3	9/16	2.028	2500	42	8030833	
	D1-4	5/8	2.165	2500	42	8030834	
	D1-5	3/4	2.165	2500	42	8030835	
	D1-6	7/8	2.165	2500	42	8030836	
10"	D1-5	3/4	2.992	2000	71	8031035	
	D1-6	7/8	2.992	2000	71	8031036	
	D1-8	1	2.992	2000	71	8031038	
12-1/2"	D1-6	7/8	4.055	1500	112	8031236	
	D1-8	1	4.055	1500	112	8031238	
	D1-11	1-3/16	4.055	1500	112	8031239	
15-3/4"	D1-6	7/8	4.055	1000	223	8031636	
	D1-8	1	5.354	1000	223	8031638	
	D1-11	1-3/16	5.354	1000	223	8031639	
20"	D1-8	1	5.354	700	331	8032038	
	D1-11	1-3/16	7.598	700	331	8032039	
25"	D1-11	1-3/16	7.598	500	604	8032539	

"L" Type Mount (3255)

Chuck Dia.	Taper Size	Hole Dia.	RPM max.	Weight lbs.	Order No.	Price
6-1/4"	L00	2.20	3000	23	8040641	
	L0	2.60	3000	23	8040642	
8"	L00	2.20	2500	42	8040841	
	L0	2.60	2500	42	8040842	
	L1	3.35	2500	42	8040843	
10"	L0	2.60	2000	64	8041042	
	L1	3.35	2000	64	8041043	
	L2	4.29	2000	64	8041044	
12-1/2"	L0	2.60	1500	134	8041242	
	L1	3.35	1500	134	8041243	
	L2	4.29	1500	134	8041244	
15-3/4"	L1	3.35	1000	251	8041643	
	L2	4.29	1000	251	8041644	



Threaded (3285/3284)

*Solid Jaws

Chuck Dia.	Thread Dia.	Hole Dia.	RPM max.	Weight lbs.	Order No.	Price
4"*	1" - 10	.79	3500	8.8	8050451	
	1-1/2" - 8	.79	3500	8.8	8050452	
5"	1" - 10	1.26	3200	12	8050551	
	1-1/2" - 8	1.26	3200	12	8050552	
6-1/4"	1-1/2" - 8	1.57	3000	23	8050652	
	2-1/4" - 8	1.57	3000	23	8050653	
8"	1-1/2" - 8	2.17	2500	45	8050852	
	2-1/4" - 8	2.17	2500	45	8050853	
	2-3/8" - 6	2.17	2500	45	8050854	
10"	2-1/4" - 8	2.99	2000	75	8051053	
12-1/2"	2-3/8" - 6	4.06	1500	121	8051254	
	2-3/4" - 8	4.06	1500	121	8051255	

4" only (Solid Jaw)



UNIVERSAL THREE-JAW SELF-CENTERING SCROLL CHUCKS SPARE PARTS SERIES 287:



MACHINE TOOL ACCESSORIES

Chuck Dia.	Hard Master Jaws 3 Pc. Set		Hard Top Jaws 3 Pc. Set		OD Jaws 3 Pc. Set		ID Jaws 3 Pc. Set		Soft Solid Jaws 3 Pc. Set		3, 4, 6 Jaw Soft Top Jaws 1 Pc.	
	Order No.	Price	Order No.	Price	Order No.	Price	Order No.	Price	Order No.	Price	Order No.	Price
3"	-		-		7880303		7881303		7882303		-	
4"	-		-		7880304		7881304		7882304		-	
5"	7885305		7883305		7880305		7881305		7882305		7884305	
6-1/4"	7885306		7883306		7880306		7881306		7882306		7884306	
8"	7885308		7883308		7880308		7881308		7882308		7884308	
10"	7885310		7883310		7880310		7881310		7882310		7884310	
12-1/2"	7885312		7883312		7880312		7881312		7882312		7884312	
15-3/4"	7885316		7883316		7880316		7881316		7882316		7884316	
20"	7885320		7883320		7880320		7881320		7882320		7884320	
25"	7885325		7883325		7880325		7881325		7882325		7884325	
32"	7885332		7883332		-		-		-		7884325	



Chuck Dia.	Scroll		Pinion		Wrench			Pinion Screw	
	2-3-4 Jaw Order No.	Price	2-3-4 Jaw Order No.	Price	2-3-4 Jaw Order No.	Square Size	Price	2-3-4Jaw Order No.	Price
3"	7887303		7886303		7889003	.2344		7888904	
4"	7887304		7886304		7889005	.3543		7888904	
5"	7887305		7886305		7889005	.3543		7888906	
6-1/4"	7887306		7886306		7889008	.4331		7888906	
8"	7887308		7886308		7889008	.4331		7888910	
10"	7887310		7886310		7889012	.5512		7888910	
12-1/2"	7887312		7886312		7889012	.5512		7888910	
15-3/4"	7887316		7886316		7889016	.6693		7888920	
20"	7887320		7886320		7889025	.7480		7888920	
25"	7887325		7886325		7889025	.7480		7888920	
32"	7887332		7886332		7889332	.7480		7888920	

All above spare parts sold by piece.

TWO-JAW SELF-CENTERING SCROLL CHUCKS

SERIES 284:

These modern Bison, Two-Jaw, precision lathe chucks can be used on all types of lathes and with different kinds of milling, drilling, CNC attachments. Chucks are provided with **American Standard Two-Piece Tongue & Groove Jaws**. Soft top jaws are shaped by user to fit the workpiece.

BODY - is made of high quality cast iron. All guideways and bearing surfaces are precisely machined.

SCROLL PLATE - drop forged of fine alloy steel, carefully case hard. Thread flanks ground on both sides.

MASTER JAWS - the teeth and guides are hardened and fully ground on both sides.

PINIONS - hardened and ground.

Standard Accessories:

- 1 set of two-piece reversible jaws (soft top jaws and hard master jaws),
- 1 self - ejecting wrench, 1 set of mounting screws,
- 2 hex keys.

Adapter plates see pages 557, 558.

All spare parts available; please inquire.



PLAIN BACK (3105)

Chuck Dia.	Hole Dia.	RPM max.	Weight lbs.	Order No.	Price
6-1/4"	1.65	3000	19.0	8300600	
8"	2.17	2500	34.0	8300800	
10"	2.99	2000	57.0	8301000	
12-1/2"	4.06	1500	96.0	8301200	
15-3/4"	5.35	1000	176	8301600	

FOUR-JAW, SELF-CENTERING SCROLL CHUCKS, PLAIN BACK

SERIES 283:



Solid Jaws

3605 Universal and 3705 Precision, Four-Jaw, Scroll Lathe Chucks with two-piece hard reversible jaws. Semi-steel body or Forged Steel Body. Scroll and jaws hardened and ground.

Standard Accessories:

1 set of two-piece reversible jaws (hard top jaws and hard master jaws),
1 wrench, 1 set of mounting screws.

3604 Universal, Four-Jaw, Scroll Lathe Chucks with two-sets of hard solid jaws. Semi-steel body. Scroll and jaws hardened and ground.

Standard Accessories:

2 sets of hard solid jaws (inside and outside), 1 wrench, 1 set of mounting screws.

Optional Accessories:

Soft solid jaws.

Adapter Plates see pages 557-558.
All spare parts available; please inquire.

Chuck Dia.	Hole Dia.	Semi - Steel Body							Forged Steel Body			
		RPM Max.	2 pc. Jaws (3605)			Solid Jaws (3604)			2 pc. Jaws (3705)			
			Wt. lbs.	Order No.	Price	Wt. lbs.	Order No.	Price	RPM Max.	Weight lbs.	Order No.	Price
5"	1.26	3200	10	8400500		9.3	8450500		-	-	-	
6-1/4"	1.65	3000	19	8400600		17	8450600		4500	21	8410600	
8"	2.17	2500	34	8400800		32	8450800		4000	36	8410800	
10"	2.99	2000	57	8401000		52	8451000		3500	75	8411000	
12-1/2"	4.06	1500	96	8401200		87	8451200		2800	123	8411200	
15-3/4"	5.35	1000	176	8401600		163	8451600		2000	198	8411601	
20"	7.48	700	295	8402000		271	8452000		1200	331	8412000	
25"	9.92	500	529	8402500		-	-		1000	560	8412500	

LARGE THROUGH-HOLE THREE-JAW SELF-CENTERING SCROLL CHUCKS, PLAIN BACK

SERIES 267:

STEEL & SEMI-STEEL BODY

Universal, Three-Jaw, Scroll Lathe Chucks with large through hole. Two-piece reversible tongue and groove jaws. Semi-steel body or steel body. Plain back mount. Jaws, scroll plate and pinions are made of fine alloy steel, carefully heat treated and ground; balanced scroll. Chucks are available with 10-1/2" through-hole which can be increased by the user to 12-1/2".

Standard Accessories:

1 set of two-piece reversible jaws (hard top jaws and hard master jaws),
1 wrench, 1 set of mounting screws.

Optional Accessories:

Soft top jaws.



Adapter Plates see pages 557-558.

3205/3307

Chuck Dia.	Chuck Body	Hole Dia.	R.P.M. max.	Weight lbs.	Order No.	Price
31-1/2"	semi-steel	10-1/2"	300	738	8003200	
	steel		450	772	8203200	

EXTRA LARGE THROUGH-HOLE THREE-JAW SELF-CENTERING SCROLL CHUCKS, PLAIN BACK

SERIES 267:

Large Diameter through-hole Chucks are designed for pipe machining or pipe welding/cut off operations. They can also be used on lathes, rotary tables, welding devices.

Two-piece reversible American Standard Tongue and Groove jaws. Semi-steel body. Plain back mount. Jaws, scroll plate and pinions are made of fine alloy steel, heat treated and ground. Balanced scroll.

Standard Accessories:

1 set of master jaws.
1 wrench, 1 set of mounting screws.

Optional Accessories:

Hard top jaws.
Soft top jaws.



Adapter Plates see pages 557-558.

3295

Chuck Dia.	Hole Dia.	Jaw Stroke		Weight lbs.	R.P.M. max.	Order No.	Price
		min.	max.				
16"	8.66	6.61	11.34	127	500	8191600	
20"	12.60	9.87	14.96	167	350	8192000	
26"	15.98	14.80	19.57	300	250	8192600	

FRONT MOUNTING 3 & 4 JAW SELF-CENTERING SCROLL CHUCKS, PLAIN BACK

SERIES 283:

3275



3274



3675



3 and 4-Jaw Universal Scroll Chucks are designed for use with rotary tables and other devices where back mounting chucks cannot be used.

They can be mounted directly on 3-slot rotary tables or on base plates when rotary table has 4 or 8 T-slots.

Chuck Dia.	Hole Dia.	Weight lbs.	3 - Jaw				4 - Jaw	
			Solid Jaws		2 pc. Jaws		Order No. (3675)	Price
			Order No. (3274)	Price	Order No. (3275)	Price		
4"	0.7874	5.3	8110400		-		-	
5"	1.2598	9.3	8110500		8120500		8140500	
6-1/4"	1.6535	17.0	8110600		8120600		8140600	
8"	2.1654	32.0	8110800		8120800		8140800	
10"	2.9921	52.0	8111000		8121000		8141000	
12-1/2"	4.0551	87.0	8111200		8121200		8141200	

All spare parts available; please inquire.

MINI THREE-JAW, SELF CENTERING SCROLL CHUCKS

SERIES 267:



WITH HARD REVERSIBLE JAWS, STEEL BODY

Special compact design to achieve very small turned diameters. These Chucks are suitable for EMCO, UNIMAT 3 & Prazi MD200 Lathes with threaded spindle.

Mounting Thread M14 x 1.

Standard Accessories:

1 set of hard solid reversible jaws and 1 chuck wrench.

Optional Accessories:

1 set of solid jaws.



3286

Chuck Dia.	Weight w/Wrench lbs.	Clamping Ranges min.-max.	Chuck Order No.	Price
2-1/3"	.98	.02 - 2.36	8100214	

THREE JAW & SIX JAW "SET-TRU" SCROLL CHUCKS

SERIES 642:

With Fine Adjustment,
Forged Steel Body,
3 - pinion design.



Chuck -
back view



3565



3865



BISON "SET-TRU" chucks can be used for many machining operations for which universal scroll chucks are unsuitable and all operations for which universal chucks are used. 6-jaw grips firmly with less pressure and less distortion per jaw. Ideal for thin wall and second operation work. Eliminates the need for spring collets.

Outstanding accuracy, versatility and long life make **BISON "SET-TRU"** chucks invaluable in the modern workshop and indispensable in the toolroom.

- 4 micro adjustment screws provide .0004" T.I.R. repeatability.
- 16", 20" & 25" 3- & 6-jaw chucks use 8 micro adjustment screws.
- Extremely high gripping concentricity.
- 2-piece top & master jaws are **American Standard Tongue & Groove**.
- 4" chuck has 2 sets of solid jaws.
- Chuck body - made of high quality **forged steel**, is safe at high lathe speeds.
- **Forged scroll** fully hardened with thread flanks ground on both sides for longer life and higher accuracy.
- Each scroll is precisely balanced.
- Jaws - the teeth and guides on both sides are fully hardened and ground.
- Hardened and ground bushings are pressed into the pinion seats.
- 3 pinions are hardened and ground.
- Each chuck is **balanced** within fine limits.
- Steel adapter plates for the same size of **BISON "SET-TRU"** chuck are interchangeable so that one chuck can be used on different spindles.
- The life of **BISON "SET-TRU"** chucks is approximately **2.5 times** longer than universal chucks.

3 & 6 Jaw Chucks With American Standard Two-Piece Tongue & Groove Jaws.

Chuck Dia.	Hole Dia.	3 - Jaw (3565)				6 - Jaw (3865)			
		RPM max.	Wt. lbs.	Order No.	Price	RPM max.	Wt. lbs.	Order No.	Price
4"*	.787	4200	7.3	8660400		-	-	-	
5"	1.378	3800	11	8660500		3000	13.7	8680500	
6-1/4"	1.654	3500	21	8660600		2500	25	8680600	
8"	2.165	3100	35	8660800		2200	42	8680800	
10"	2.992	2700	59	8661000		1900	78	8681000	
12-1/2"	4.955	2200	105	8661200		1500	128	8681200	
15-3/4"	5.354	1800	201	8661600		1300	250	8681600	
20"	7.480	1200	374	8662000		800	365	8682000	
25"	9.921	1000	630	8662500		700	647	8682500	

Standard Accessories:

4" - 2 sets of hard solid jaws (OD & ID)
5" - 25" - 1 set of two-piece reversible jaws (hard top jaws and hard master jaws) 1 wrench, 1 set of mounting bolts, 2 hex keys, 1 set of fine adjustment screws.

Optional Accessories:

Soft top jaws, solid ID & OD jaws. Rotating Body for 4", 5" & 6".

Spare Parts see page 551,
& Adapter Plates see page 559.

* 2 sets of hard solid jaws

SPARE PARTS FOR "SET-TRU" CHUCKS

SERIES 287:

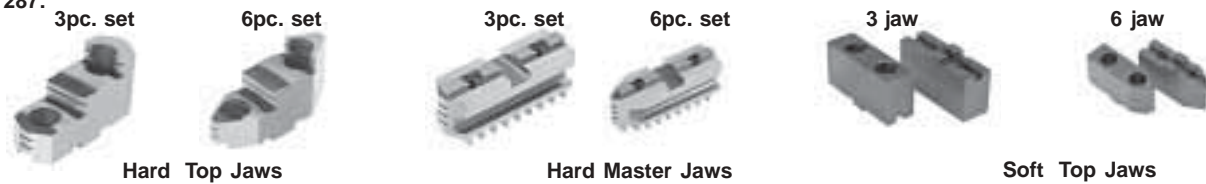

Chuck Dia.	(Sold in Sets)				(Sold in Sets)				(Sold by Piece)			
	3-Jaw Chucks	Price	6-Jaw Chucks	Price	3-Jaw Chucks	Price	6-Jaw Chucks	Price	3-Jaw Chucks	Price	6-Jaw Chucks	Price
5"	7883305		7883605		7885305		7885605		7884305		-	
6"	7883306		7883606		7885306		7885606		7884306		7884606	
8"	7883308		7883608		7885308		7885608		7884308		7884608	
10"	7883310		7883610		7885310		7885610		7884310		7884610	
12"	7883312		7883612		7885312		7885612		7884312		7884612	
16"	7883316		7883616		7885316		7885616		7884316		7884616	
20"	7883320		7883620		7885320		7885620		7884320		-	
25"	7883325		7883625		7885325		7885625		7884325		-	



Chuck Dia.	Scroll		Pinion		Wrench			Pinion Sleeve		Half Ring	
	3 & 6 Jaw Order No.	Price	3 & 6 Jaw Order No.	Price	3 & 6 Jaw Order No.	Square Size	Price	3 & 6 Jaw Order No.	Price	3 & 6Jaw Order No.	Price
4"	7887304		7886304		7889005	.35		-		7888904*	
5"	7887505		7886505		7889005	.35		7888505		7888705	
6"	7887506		7886506		7889008	.43		7888506		7888706	
8"	7887508		7886508		7889008	.43		7888508		7888708	
10"	7887510		7886510		7889012	.55		7888510		7888710	
12"	7887512		7886512		7889012	.55		7888512		7888712	
16"	7887516		7886516		7889016	.67		7888516		7888716	
20"	7887520		7886520		7889020	.75		7888520		7888720	
25"	7887525		7886525		7889025	.75		7888525		7888725	

All above spare parts sold by the piece.

* Pinion Retaining Screw

ACCURACY OF BISON SELF-CENTERING SCROLL CHUCKS

All allowable runouts which are specified below concern measurements at three different jaw openings d (1, 2, and 3).

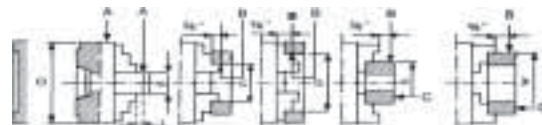

Size of Chuck D	Universal and Precision Chucks Series 3200, 3500, 3600, and 3700								
	d			L	n	p	s	w*	w**
	1	2	3						
3-1/2"	.39	-	.55	1.57	1.57	2.36	1.38	2.48	-
4"	.39	.55	.71	1.57	1.57	2.95	1.97	3.15	-
5"	.71	.98	1.18	2.36	1.97	3.94	2.44	3.94	4.72
6-1/4"	.71	1.18	1.57	2.36	1.97	5.31	3.46	3.94	5.90
8"	1.18	1.57	2.08	3.15	3.15	6.38	3.78	6.30	7.28
10"	1.18	2.08	2.95	3.15	3.15	7.87	5.90	6.30	8.86
12-1/2"	2.08	2.95	3.94	4.72	4.92	9.92	8.27	9.84	11.81
15-3/4"	2.08	3.94	4.92	4.72	4.92	11.10	9.84	9.84	13.78
20"	2.95	3.94	4.92	6.30	7.87	11.10	11.81	15.75	15.75
25"	2.95	4.92	6.30	6.30	7.87	12.79	15.75	15.75	15.75
31-1/2"	6.30	7.87	9.84	6.30	12.80	19.70	15.75	19.70	19.70

Size of Chuck	Runouts on Universal and Precision Chucks		
	Radial Runout		Axial Runout
	A	B	C
3-1/2"	.0008	.0010	.0006
4"	.0008	.0010	.0006
5"	.0012	.0014	.0008
6-1/4"	.0012	.0014	.0008
8"	.0016	.0018	.0010
10"	.0016	.0018	.0010
12-1/2"	.0020	.0022	.0012
15-3/4"	.0024	.0025	.0012
20"	.0040	.0040	.0020
25"	.0040	.0040	.0020
31-1/2"	.0059	.0059	.0024

*For solid jaws **For two-piece jaws

PERMISSIBLE SPINDLE RUNOUT

Radial Runout A
.0002

Axial Runout B
.00012



Short Taper Long Taper

For spindle noses: A, D & L.
For threaded spindles: See Chuck Manual.

NOTE!

To obtain the specified clamping accuracy of a chuck mounted on a machine tool, it is necessary:

- to reduce play in the spindle bearings to the allowable minimum
- to ensure the machine spindle nose runout not exceed the values specified
- to meet the basic requirements for correct mounting of chuck on the

THREE-JAW SELF-CENTERING SCROLL CHUCKS, FORGED STEEL

SERIES 276:

Precision lathe chucks have top accuracy and the guarantee to maintain this accuracy for an extended period of time. These chucks have a modern and compact design. They are able to fulfill the highest demands of our customers. They can be used wherever precision and high precision machining is demanded.

BODY - drop-forged of highest grade steel and put through precise machining operations. All bearings surfaces are carefully hardened and precisely ground.

SCROLL PLATE - drop-forged of fine alloy steel and carefully case hardened. Thread flanks are ground on both sides.

JAWS - the teeth and guides are hardened and fully ground on both sides.

PINIONS - hardened and ground.

BUSHINGS - hardened and ground, pressed into the pinion seats. Jaws, pinions and bushings are made of fine alloy steel. Precision grinding of scroll and jaws teeth will permit you to:

- eliminate possible deformation as a result of heat treatment
- reach uniform radial gripping force on all teeth of jaws
- increase guarantee period for high centering accuracy
- increase gripping force

Each chuck is provided with lubricator enabling current maintenance and extending chuck components life. Each scroll and assembled chuck is statically balanced within fine limits.

Interstage and final inspection assure high quality of our chucks.

Standard Accessories:

- 4" - 2 sets of hard solid jaws (inside and outside)
- 5" - 25" - 1 set of two-piece reversible jaws (hard top jaws and hard master jaws).
- 1 wrench, 1 set of mounting screws

Optional Accessories:

- Soft top jaws. Solid I.D. & O.D. jaws.



See page 551 for accuracy and runout specifications.



AMERICAN STANDARD TONGUE & GROOVE JAWS.



32" STEEL BODY CHUCK

Note: Plain back chucks require adapter plates which may require machining to fit.

Plain Back (3505)

Chuck Dia.	Hole Dia.	RPM max.	Weight lbs.	Order No.	Price
5"	1.26	4800	10	8200500	
6-1/4"	1.65	4500	21	8200600	
8"	2.17	4000	36	8200800	
10"	2.99	3500	75	8201000	
12-1/2"	4.06	2800	123	8201200	
15-3/4"	5.35	2000	198	8201600	
20"	7.48	1200	276	8202000	
25"	9.92	1000	485	8202500	
32"	See Page 549				

Spare Parts see page 553.

& Adapter Plates see pages 557-558.



CHUCK GREASE
Order No. 7799025
Price:



A-1/A-2 TYPE MOUNT (3515)

Chuck Dia.	Taper Size	Hole Dia.	RPM max.	Wt. lbs.	Order No.	Price
6-1/4"	A1-5	1.65	4500	22	8210615	
8"	A1-5	1.65	4000	42	8210815	
	A1-6	2.17	4000	42	8210816	
10"	A1-6	2.17	3500	71	8211016	
	A1-8	2.99	3500	71	8211018	
12-1/2"	A2-6	4.06	2800	121	8211226	
	A1-8	3.15	2800	121	8211228	
15-3/4"	A2-8	5.35	2000	203	8211628	
	A1-11	5.12	2000	203	8211629	
20"	A2-8	5.35	1200	353	8212028	
	A2-11	7.48	1200	353	8212029	
25"	A2-11	7.48	1000	628	8212529	
	A2-15	9.92	1000	628	8212530	

D-1 TYPE MOUNT (3545)

Chuck Dia.	Taper Size	Stud Dia.	Hole Dia.	RPM max.	Weight lbs.	Order No.	Price
6-1/4"	D1-3	9/16	1.65	4500	20	8230633	
	D1-4	5/8	1.65	4500	20	8230634	
	D1-5	3/4	1.65	4500	20	8230635	
8"	D1-5	3/4	2.17	4000	42	8230835	
	D1-6	7/8	2.17	4000	42	8230836	
10"	D1-6	7/8	2.99	3500	71	8231036	
	D1-8	1	2.99	3500	71	8231038	
12-1/2"	D1-6	7/8	4.06	2800	112	8231236	
	D1-8	1	4.06	2800	112	8231238	
	D1-11	1-3/16	4.06	2800	112	8231239	
15-3/4"	D1-8	1	5.35	2000	223	8231638	
	D1-11	1-3/16	5.35	2000	223	8231639	
20"	D1-8	1	5.35	1200	331	8232038	
	D1-11	1-3/16	7.48	1200	331	8232039	
25"	D1-8	1	5.35	1000	604	8232538	
	D1-11	1-3/16	7.48	1000	604	8232539	

FORGED STEEL SCROLL CHUCKS

SPARE PARTS

SERIES 287:



Chuck Dia.	Hard Master Jaws 3 Pc. Set		Hard Top Jaws 3 Pc. Set		OD Jaws 3 Pc. Set		ID Jaws 3 Pc. Set		Soft Solid Jaws 3 Pc. Set		Soft Top Jaw 1 Pc.	
	Order No.	Price	Order No.	Price	Order No.	Price	Order No.	Price	Order No.	Price	Order No.	Price
5"	7885305		7883305		7880305		7881305		7882305		7884305	
6-1/4"	7885306		7883306		7880306		7881306		7882306		7884306	
8"	7885308		7883308		7880308		7881308		7882308		7884308	
10"	7885310		7883310		7880310		7881310		7882310		7884310	
12-1/2"	7885312		7883312		7880312		7881312		7882312		7884312	
15-3/4"	7885316		7883316		7880316		7881316		7882316		7884316	
20"	7885320		7883320		7880320		7881320		7882320		7884320	
25"	7885325		7883325		7880325		7881325		7882325		7884325	



Chuck Dia.	Scroll		Pinion		Wrench			Pinion Sleeve		Half Ring	
	Order No.	Price	Order No.	Price	Order No.	Square Size	Price	Order No.	Price	Order No.	Price
5"	7887505		7886505		7889005	.35		7888505		7888705	
6-1/4"	7887506		7886506		7889008	.43		7888506		7888706	
8"	7887508		7886508		7889008	.43		7888508		7888708	
10"	7887510		7886510		7889012	.55		7888510		7888710	
12-1/2"	7887512		7886512		7889012	.55		7888512		7888712	
15-3/4"	7887516		7886516		7889016	.66		7888516		7888716	
20"	7887520		7886520		7889025	.75		7888520		7888720	
25"	7887525		7886525		7889025	.75		7888525		7888725	

All above spare parts sold by the piece.

4 - JAW INDEPENDENT CHUCKS

SERIES 995:

The chuck body is made of cast iron. The reversible jaws and operating screw are made of high quality carbon steel, hardened and precision ground.



4 - JAW INDEPENDENT THREADED BACK CHUCKS



6" Diameter 4-Jaw Independent Plain Back Chuck PLUS 6" x 1.1/2"-8 or 2-1/4-8 Finished Backplate made for the chuck mounts instantly (Chuck can be used by itself or with included back plate.) Chuck body is made of high quality semi-steel. Hardened and ground scroll. Heat treated operation screws. Includes chuck wrench and mounting screws.



Plain Back

Chuck Dia.	Thru Hole	Order No.	Price
6"	1-1/2"	6251006	
8"	1-15/16"	6251008	
10"	2-1/2"	6251010	
12"	3-3/4"	6251012	
16"	3-1/2"	6251016	

D-1 Type Mount

Chuck Dia.	Spindle	Thru Hole	Order No.	Price
8"	D1-4	2.165"	6250804	
10"	D1-4	2.953"	6251104	
10"	D1-6	2.953"	6251106	
12"	D1-6	3.740"	6251206	
16"	D1-8	4.921"	6251608	

Chuck Dia.	Thru Hole	Order No.	Price
6"	1-1/2-8	6250612	
6"	2-1/4-8	6250622	

FOUR-JAW INDEPENDENT LATHE CHUCKS

SERIES 279: SEMI-STEEL BODY
SERIES 268: STEEL BODY

BISON medium duty and heavy duty, 4-Jaw independent chucks are designed to grip round or odd shaped work.
 Medium duty chuck has semi-steel body and hard solid reversible jaws (36" has two-piece hard reversible jaws).
 Heavy duty has steel body and two-piece hard reversible jaws.
 Solid jaws are made of high quality carbon steel and hardened.
 Hard Top and Hard Master Jaws are made of high quality alloy steel, hardened and ground.

Larger Diameter chucks (from 10" to 49") are supplied with T-slots.



Four jaw, steel body independent Lathe Chucks with two-piece reversible hard jaws.

Standard Accessories:
 1 set of two-piece reversible jaws (hard top jaws and hard master jaws),
 1 wrench, 1 set of mounting bolts.



Optional Accessories:
 Soft jaws.



Four jaw semi-steel body Lathe Chucks with hard solid reversible jaws.

Standard Accessories:
 Chuck with Dia. 3-1/2" to 32" are provided with 1 set of hard solid reversible jaws, 1 wrench, 1 set of clamping bolts.
 36" chuck is provided with two-piece reversible jaws (hard top jaws and hard master jaws).

Optional Accessories:
 Hard top jaws, hard master jaws and soft top jaws.

Adapter Plates: (Note: Some machining is required.)
 See pages 557-558.

Spare Parts:
 See page 556.



Plain Back

4304

4303

Chuck Dia.	Hole Dia.	Semi-Steel			Steel*		
		Weight lbs.	Order No.	Price	Weight lbs.	Order No.	Price
3-1/2"***	1.000	3.4	8500300		-	-	
5"***	1.0236	8.0	8500500		-	-	
6-1/4"	1.6535	9.0	8500600		-	-	
8"	1.9685	32	8500800		35	8550800	
10"	2.5591	55	8501000		59	8551000	
12-1/2"	3.1496	88	8501200		95	8551200	
15-3/4"	3.9370	139	8501600		150	8551600	
20"	4.9313	231	8502000		250	8552000	
25"	6.2992	364	8502500		390	8552500	
32"	7.8740	700	8503200		750	8553200	
32"/T	10.500	672	8503300		-	-	
36"	7.4809	800	8503600*		856	8553600	
40"	7.4809	-	-		1367	8554000	
49"	7.4809	-	-		2138	8554900	

CHUCK GREASE
Order No. 7799025
Price:



*With two-piece jaws.
 **Steel body.

NOTE: Plain back chucks require adapter or back plate which require machining to fit.



"L" TYPE MOUNT*

4354

Chuck Dia.	Taper Dia.	Hole Dia.	Weight lbs.	Order No.	Price
8"	L00	1.96	34	8540841	
8"	L0	1.96	34	8540842	
10"	L00	2.56	57	8541041	
10"	L0	2.56	57	8541042	
10"	L1	2.56	57	8541043	
12-1/2"	L0	3.15	119	8541242	
12-1/2"	L1	3.15	119	8541243	
12-1/2"	L2	3.15	119	8541244	
15-3/4"	L1	3.93	154	8541643	
15-3/4"	L2	3.93	154	8541644	
20"	L2	4.92	256	8542044	

*Semi-Steel only.

(Continued)

FOUR-JAW INDEPENDENT LATHE CHUCKS (Continued)

SERIES 279: SEMI-STEEL BODY
 SERIES 268: STEEL BODY



A1/A2 TYPE MOUNT

4314

4313



Chuck Dia.	Taper Dia.	Hole Dia.	Weight lbs.	Semi-Steel Order No.	Price	Weight lbs.	Steel Order No.	Price
8"	A2-5	1.969	38	9510815			-	
8"	A2-6	1.969	38	9510816		41	8560816	
10"	A2-5	2.559	56	8511025			-	
10"	A2-6	2.559	56	0911016		60	8561016	
10"	A2-8	2.559	56	9911018		60	8561018	
12-1/2"	A2-5	3.150	88	8511215			-	
12-1/2"	A2-6	3.150	88	8511226		94	8561216	
12-1/2"	A2-8	3.150	88	8511218		94	8561218	
15-3/4"	A2-6	3.937	143	8511626		153	8561616	
15-3/4"	A2-8	3.937	143	8511628		153	8561618	
15-3/4"	A2-11	3.937	143	8511619		153	8561619	
20"	A2-8	4.921	251	-		269	8562018	
20"	A2-11	4.921	251	8512019		269	8562019	
20"	A2-15	4.921	251	-		269	8562020	
25"	A2-11	6.299	364	9512519		389	8562519	
25"	A2-15	6.299	364	-		389	8562520	
32"	A2-11	6.299	672	8513219		719	8563219	
32"	A2-15	6.299	672	-		719	8563220	
40"	A2-15	6.693		-		744	8564015	



D1 TYPE MOUNT

4344

4343

Chuck Dia.	Taper Size	Stud Dia.	Stud Qty.	Hole Dia.	Weight lbs.	Semi-Steel Order No.	Price	Weight lbs.	Steel Order No.	Price
8"	D1-3	9/16	3	3.150	37	8530833		-	-	
8"	D1-4	5/8	3	3.150	37	8530834		40	8570834	
8"	D1-5	3/4	6	3.150	37	8530835		40	8570835	
8"	D1-6	7/8	6	3.150	-	-		40	8570836	
10"	D1-4	5/8	3	3.346	61	8531034		-	-	
10"	D1-5	3/4	6	3.346	61	8531035		65	8571035	
10"	D1-6	7/8	6	3.346	61	8531036		65	8571036	
10"	D1-8	1	6	3.346	-	-		65	8571038	
12-1/2"	D1-6	7/8	6	3.740	87	8531236		93	8571236	
12-1/2"	D1-8	1	6	3.740	87	8531238		93	8571238	
15-3/4"	D1-6	7/8	6	4.134	132	8531636		141	8571636	
15-3/4"	D1-8	1	6	4.134	132	8531638		141	8571638	
15-3/4"	D1-11	1-3/16	6	4.134	132	8531639		141	8571639	
20"	D1-8	1	6	4.724	211	8532038		226	8572038	
20"	D1-11	1-3/16	6	4.724	211	8532039		226	8572039	
20"	D1-15	1-3/8	6	4.724	-	-		226	8572040	
25"	D1-8	1	6	5.512	364	8532539		389	8572538	
25"	D1-11	1-3/16	6	5.512	-	-		389	8572539	
25"	D1-15	1-3/8	6	5.512	-	-		389	8572540	
32"	D1-11	1-3/16	6	6.199	-	-		703	8573239	
32"	D1-15	1-3/8	6	6.199	-	-		703	8573240	

SPARE PARTS FOR FOUR - JAW INDEPENDENT LATHE CHUCKS SERIES 296:



Chuck Dia.	Hard Reversible Jaws		Hard Master Jaws		Hard Solid Jaws		Medium Soft Top Jaws /1pc.	
	Order No.	Price/ Each	Order No.	Price/ Each	Order No.	Price/ Each	Order No.	Price/ Each
3-1/2"	-		-		8901030		-	
5"	-		-		8901050		7884305	
6-1/4"	-		-		8901060		7884306	
8"	7890208		7890308		8901080		7884308	
10"	7890210		7890310		8901100		7884310	
12-1/2"	7890212		7890312		8901120		7884312	
15-3/4"	7890216		7890316		8901160		7884316	
20"	7890220		7890320		8901200		7884320	
25"	7890225		7890325		8901250		7884325	
32"	7890232		7890332		8901320		7884325	
32"/T	7890232		7890332		8901320		7884325	
36"	7890236		7890336		-		7884332	
40"	7890236		7890336		-		7884332	
49"	7890236		7890336		-		7884332	

All above spare parts sold by piece.



Chuck Dia.	Heavy Duty Soft Top Jaws		Operating Screws		Thrust Bearing		Wrench	
	Order No.	Price	Order No.	Price	Order No.	Price	Order No.	Price
3-1/2"	-		7890603		7890703		-	
5"	-		7890606		7890706		7890906	
6-1/4"	7884206		7890606		7890706		7890906	
8"	7884208		7890608		7890708		7890910	
10"	7884210		7890610		7890710		7890910	
12-1/2"	7884212		7890612		7890712		7890916	
15-3/4"	7884216		7890616		7890716		7890916	
20"	-		7890620		7890720		7890925	
25"	-		7890625		7890725		7890925	
32"	-		7890632		7890732		7890932	
32"/T	-		7890633		7890732		7890932	
36"	-		7890636		7890736		7890932	
40"	-		7890640		7890736		7890932	
49"	-		7890649		7890736		7890932	

All above spare parts sold by piece.

FOUR-JAW COMBINATION LATHE CHUCKS

SERIES 270:

BISON Plain Back combination chucks combine the advantages of a scroll chuck and an independent chuck in one. Each jaw may be adjusted individually with an independent operating screw. After the desired eccentric setting has been made, all jaws can then be opened and closed simultaneously with the use of a scroll and pinion. The jaws are reversible and may be used as both inside and outside jaws.

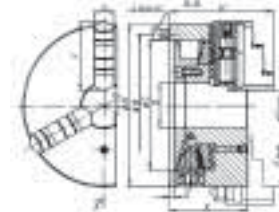

4605

4805

Standard Accessories:

1 set of hard solid reversible jaws, 1 wrench, 1 set of mounting screws.



Optional Accessories:

Soft solid jaws.



Adapter Plates:

See pages 557-558.

Chuck Dia.	Hole Dia.	Semi-Steel				Steel			
		RPM	Weight lbs.	Order No.	Price	RPM	Wt. lbs.	Order No.	Price
8"	2.17	2000	41.4	8480800		2500	43.0	8490800	
10"	2.99	1800	65.0	8481000		2000	68.3	8491000	
12-1/2"	4.05	1500	120	8481200		1700	124	8491200	
15-3/4"	5.35	1000	194	8481600		1500	198	8491600	
20"	7.351	500	330	8482000		1000	342	8492000	
25"	9.92	350	551	8482500		750	573	8492500	

5C ADAPTERS FOR BISON LATHE CHUCKS

SERIES 291:

SEMI-FINISHED

5C Adapters are designed for use with Self-Centering or Independent Lathe Chucks.

Made of high quality forged steel. 5C shank is hardened and precision ground for maximum accuracy.

Soft flange. Wide clamping range and high accuracy makes them very useful in many precision drilling, turning, grinding and milling operations.

BISON Chucks and 5C Adapters give accuracy not available with standard and precision 5C collets.

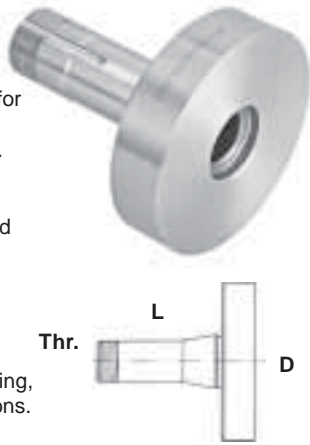

5C						For use with the following Lathe Chucks		
Shank	Flange Dia. D	Hole D	L	Order No.	Price	Chuck Dia.	3 & 4 Jaw Order No.	4 Jaw Order No.
5C	4"	.866	4.41	7909304		3" & 4"	8100300	8500300
	5"			7909305			8100400	
	6"			7909306			8110400	
						5" & 6"	8000500	8500500
						6"	8100500	8500600
							8120500	
							8140500	
							8000600	
							8120600	
							8140600	

CAST-IRON ADAPTERS

SERIES 291:

NOTE: Number of camlock studs depends on spindle size. See Table.

8240

8242

D1 ADAPTERS

8240 Fully Machined Adapters for BISON plain back, self-centering Chucks - designed for direct mounting on camlock spindle noses.

8242 Semi Machined Adapters for plain back Chucks - designed for direct mounting on camlock spindle noses.



Fully Machined



Semi Machined

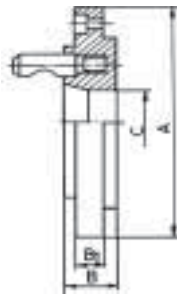

Chuck Dia.	Taper Size	Stud Dia.	No. of Studs	Hole Dia. C	Fully Machined			Semi Machined		
					Wt. lbs.	Order No.	Price	Wt. lbs.	Order No.	Price
5"	D1-3	9/16	3	2.02	5.3	7878053	-	-	-	
5"	D1-4	5/8	3	2.40	5.3	7878054	-	-	-	
6-1/4"	D1-3	9/16	3	2.02	9.5	7878063	9.3	8780630		
6-1/4"	D1-4	5/8	3	2.40	9.5	7878064	9.3	8780640		
6-1/4"	D1-5	3/4	6	3.13	9.5	7878065	9.3	8780650		
6-1/4"	D1-6	7/8	6	4.06	9.5	7878066	-	-		
8"	D1-3	9/16	3	2.02	15.4	7878083	27	8780830		
8"	D1-4	5/8	3	2.40	15.4	7878084	27	8780840		
8"	D1-5	3/4	6	3.13	15.4	7878085	27	8780850		
8"	D1-6	7/8	6	4.06	15.4	7878086	27	8780860		
10"	D1-5	3/4	6	3.13	24.3	7878105	35	8781050		
10"	D1-6	7/8	6	4.06	24.3	7878106	35	8781060		
10"	D1-8	1	6	5.35	24.3	7878108	35	8781080		
12-1/2"	D1-6	7/8	6	4.06	39.7	7878126	49	8781260		
12-1/2"	D1-8	1	6	5.35	39.7	7878128	49	8781280		
12-1/2"	D1-11	1-3/16	6	7.59	39.7	7878129	49	8781290		
15-3/4"	D1-6	7/8	6	4.06	79	7878166	93	8781660		
15-3/4"	D1-8	1	6	5.35	79	7878168	93	8781680		
15-3/4"	D1-11	1-3/16	6	7.59	79	7878169	93	8781690		
20"	D1-8	1	6	5.35	132	7878208	159	8782080		
20"	D1-11	1-3/16	6	7.59	132	7878209	159	8782090		
25"	D1-8	1	6	5.35	232	7878258	232	8782580		
25"	D1-11	13/16	6	7.59	232	7878259	232	8782590		

THREADED ADAPTERS FOR HARDINGE LATHES

8204

Chuck Dia.	Thread D	Weight lbs.	Order No.	Price
5"	M39 x 4	11	7922051	
5"	2-3/16 - 10	11	7922053	
6-1/4"	2-3/16 - 10	13	7922063	

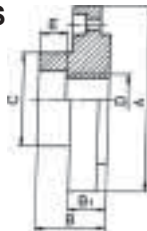

Fully Machined Adapters for BISON plain back, self-centering Chucks - designed for direct mounting on Hardinge 2-3/16" - 10 spindle noses.



CAST-IRON ADAPTERS

SERIES 291:



Semi Machined and Fully Machined Adapters for plain back chucks - designed for direct mounting on A1 and A2 spindle noses. May be used for both scroll and independent chucks.

MACHINE TOOL ACCESSORIES



Rough Adapters for Scroll Chucks

Chuck Dia.	Weight lbs.	Order No.	Price
3", 4", 5"	4.4	7870105	
6-1/4"	12	7870106	
8"	22	7870108	
10"	34	7870110	
12-1/2"	66	7870112	
15-3/4"	154	7870116	
20"	267	7870120	
25"	496	7870125	

Rough Adapters for 4 Jaw Independent Chucks

8262

Chuck Dia.	Weight lbs.	Order No.	Price
6-1/4"	8	7870306	
8"	11	7870308	
10"	25	7870310	
12-1/2"	49	7870312	
15-3/4"	95	7870316	
20", 25"	99	7870320	
32"	177	7870332	



Semi-Finished Threaded Adapters

8206

Chuck Dia.	Thread Size	Weight lbs.	Order No.	Price
4"	1-10	8	7871041	
4"	1-1/2-8	8	7871042	
5"	1-10	10	7871051	
5"	1-1/2-8	10	7871052	
6-1/4"	1-1/2-8	12	7871062	
6-1/4"	2-1/4-8	12	7871063	
8"	1-1/2-8	12	7871082	
8"	2-1/4-8	13	7871083	
8"	2-3/8 - 6	13	7871084	
10"	2-1/4-8	22	7871103	
10"	2-3/8-6	25	7871104	
12-1/2"	2-3/8-6	33	7871124	
12-1/2"	2-3/4-8	33	7871125	

A1/A2 TYPE ADAPTERS

8212

8210

Chuck Dia.	Taper No.	Weight lbs.	SemiMach. Order No.	Price	Weight lbs.	Fully Mach. Order No.	Price
5"	A-6	6.5	7873056		5.3	8730560	
5"	A-8	6.5	7873058		5.3	8730580	
6-1/4"	A-5	6.5	7873065		-		
8"	A-5	19.0	7873085		18	8730850	
8"	A-6	15.5	7873086		-		
10"	A-6	38	7873106		-		
10"	A-8	33	7873108		-		
12-1/2"	A-6	45	7873126		-		
12-1/2"	A-8	62	7873128		-		
15-3/4"	A-6	85	7873168		-		
15-3/4"	A-11	141	7873169		-		
20"	A-11	133	7873209		-		
25"	A-11	158	7873259		-		
25"	A-15	-	7873260		231	8732600	
36",40",49"	A-15	242	8733615		-		
36",40",49"	A-20	249	8733620		-		

Fully Machined Adapters for BISON plain back, self-centering Chucks - designed for direct mounting on L type spindle noses.



L TYPE ADAPTERS

8250

Chuck Dia.	Taper No.	Thread Dia.	Weight lbs.	Order No.	Price
6-1/4"	L00	3-3/4"-6	13	7879061	
6-1/4"	L0	4-1/2"-6	13	7879062	
8"	L00	3-3/4"-6	22	7879081	
8"	L0	4-1/2"-6	22	7879082	
8"	L1	6"-6	22	7873083	
10"	L00	3-3/4"-6	33	7879101	
10"	L0	4-1/2"-6	33	7879102	
10"	L1	6"-6	33	7879103	
10"	L2	7-3/4"-5	33	7879104	
12-1/2"	L0	4-1/2"-6	57	7879122	
12-1/2"	L1	6"-6	57	7879123	
12-1/2"	L2	7-3/4"-5	57	7879124	
15-3/4"	L0	4-1/2"-6	95	7879162	
15-3/4"	L1	6"-6	95	7879163	
15-3/4"	L2	7-3/4"-5	95	7879164	
15-3/4"	L3	10-3/8"-4	95	7879165	
20"	L2	7-3/4"-5	159	7879204	
20"	L3	10-3/8"-4	159	7879205	
25"	L2	7-3/4"-5	397	7879254	
25"	L3	10-3/8"-4	397	7879255	

STEEL ADAPTERS FOR "SET-THRU" CHUCKS (A & D TYPES)

SERIES 266:



D-Type

D-Type (8245)

Chuck Dia.	Taper Size	Studs		Weight lbs.	Order No.	Price
		Qty.	Dia.			
4"	D1-3	3	9/16"	3.31	7875043	
	D1-4	3	5/8"	3.97	7875044	
5"	D1-3	3	9/16"	5.95	7875053	
	D1-4	3	5/8"	5.73	7875054	
	D1-5	6	3/4"	6.92	7875055	
	D1-6	6	7/8"	13.06	7875056	
6-1/4"	D1-3	3	9/16"	10.80	7875063	
	D1-4	3	5/8"	9.92	7875064	
	D1-5	6	3/4"	9.89	7875065	
	D1-6	6	7/8"	13.00	7875066	
8"	D1-3	3	9/16"	10.36	7875083	
	D1-4	3	5/8"	10.36	7875084	
	D1-5	6	3/4"	15.87	7875085	
	D1-6	6	7/8"	17.64	7875086	
10"	D1-4	3	5/8"	18.84	7875104	
	D1-5	6	3/4"	17.64	7875105	
	D1-6	6	7/8"	28.44	7875106	
	D1-8	6	1"	32.41	7875108	
12-1/2"	D1-6	6	7/8"	28.44	7875126	
	D1-8	6	1"	47.84	7875128	
	D1-11	6	1-3/16"	52.91	7875129	
15-3/4"	D1-6	6	7/8"	29.0	7875166	
	D1-8	6	1"	27.2	7875168	
	D1-11	6	1-3/16"	26.8	7875169	
20"	D1-8	6	1"	74	7875208	
	D1-11	6	1-3/16"	78	7875209	
	D1-15	6	1-3/8"	83	7875215	
25"	D1-8	6	1"	74	7875258	
	D1-11	6	1-3/16"	78	7875259	
	D1-15	6	1-3/8"	83	7875260	

A-Type (8215)

Chuck Dia.	Taper Size	Weight lbs.	Order No.	Price
5"	A4	4.8	7874054	
	A5	4.2	7874055	
	A6	9.1	7874056	
6-1/4"	A5	6.77	7874065	
8"	A5	9.3	7874085	
	A6	13.5	7874086	
10"	A5	17.3	7874105	
	A6	17.3	7874106	
	A8	20.2	7874108	
12-1/2"	A6	27.3	7874126	
	A8	35.7	7874128	
	A11	41.20	7874129	
15-3/4"	A6	31.4	7874166	
	A8	28.8	7874168	
	A11	35.8	7874169	
20"	A8	69	7874208	
	A11	61	7874209	
	A15	76	7874215	
25"	A8	69	7874258	
	A11	61	7874259	
	A15	76	7874260	
	A20	90	7874265	



A-Type

NOTE!
THESE ADAPTERS ARE DESIGNED TO MOUNT ON A1 & A2 SPINDLES.

5C FULLY MACHINED STEEL ADAPTERS

SERIES 266:

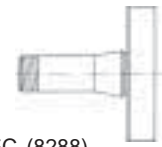

5C (8288)

T.I.R. 0.0005"



Chuck Dia.	5C Adapters	Price
4"	7-912-304	
5"	7-912-305	
6-1/4"	7-912-306	

Adapters & SET-TRU (3 & 6 Jaw) Chucks are sold separately.

*4" Solid Jaws only.

STEEL ADAPTERS FOR "SET-TRU" CHUCKS (THREADED & L TYPES)

SERIES 266:



THREADED (8285)

Chuck Dia.	D	Thread	Weight lbs.	Order No.	Price
4"	3.94	1-10 UNS-2B	4.85	7876041	
		1-1/2 - 8 UN-2B	5.29	7876042	
5"	4.92	1-10 UNS-2B	6.17	7876051	
		1-1/2 - 8 UN-2B	6.61	7876052	
		2-3/16-10 HARDINGE	7.05	7876054	
		2-1/4 - 8 UN-2B	6.8	7876056	
6-1/4"	6.30	1-1/2 - 8 UN-2B	7.05	7876062	
		2-3/16 - 10 HARDINGE	7.50	7876064	
		2-1/4 - 8 UN-2B	7.94	7876066	
8"	7.87	1-1/2 - 8 UN-2B	9.92	7876082	
		2-1/4 - 8 UN-2B	11.46	7876083	
		2-3/8 - 6 UN-2B	13.89	7876084	
10"	9.84	2-3/8 - 6 UN-2B	30.0	7876104	
12-1/2"	12.40	2-3/8 - 6 UN-2B	50.0	7876124	



L-TYPE (8255)

Chuck Dia.	D	Taper Size	Thread T-UNS3	Weight lbs.	Order No.	Price
6-1/4"	6.30	L00	3-3/4-6	9.0	7879061	
		L0	4-1/2-6	9.5	7879062	
8"	7.87	L00	3-3/4-6	15.0	7879081	
		L0	4-1/2-6	15.4	7879082	
		L1	6-6	16.5	7879083	
10"	9.84	L00	3-3/4-6	25.0	7879101	
		L0	4-1/2-6	26.1	7879102	
		L1	6-6	37.0	7879103	
12-1/2"	12.40	L0	4-1/2-6	37.0	7879122	
		L1	6-6	37.0	7879123	
		L2	7-3/4-5	38.8	7879124	
15-3/4"	11.75	L1	6-6	34.2	7879163	
		L2	7-3/4-5	45.4	7879164	
		L3	10-3/8-4	67.2	7879165	
20"	19.68	L2	7-3/4-5	60.2	7879204	
		L3	10-3/8-4	81.3	7879205	