

# MILLING MACHINE ARBORS

SERIES 358:



FOR 30 40 50 NATIONAL STANDARD TAPER SPINDLES

Milling Machine Arbors are made of top quality one piece forgings. Carefully heat treated and surfaces ground with extremely narrow tolerances assure a rigid setup and accurate machining operations. All threads are ground. Arbors are equipped with assorted solid spacers and necessary running bushings with standard keyways and threaded arbor nut.

Type A arbors are provided with end pilots 23/32 x 1-3/4".

**Drawbar Threads for:**

- #30 1/2" - 13
- #40 5/8" - 11
- #50 1" - 8

These arbors have right hand thread.

STYLE A



STYLE B

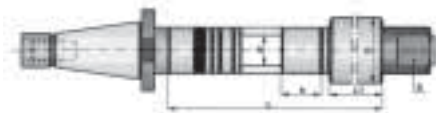

## RH ARBOR NUTS

SERIES 360:



RH nuts are hardened and have a ground thread and shoulder.

For Arbor Dia.	Thread Size	Order No.	Price
7/8	7/8 - 14RH	7030005	
1	1-14RH	7030010	
1-1/4	1-1/4 - 12RH	7030015	
1-1/2	1-1/2 - 12RH	7030020	
2	2 - 12RH	7030025	
2-1/2	2-1/2 - 12RH	7030030	

## STYLE A WITH PILOT

Arbor No.	Taper	Arbor Dia. d	Length L	Running Bushing D x L <sub>1</sub>	No. of Bushings	Order No.	Price
30-7/8 - A10-2 31-A10-2 31-1/4 - A10-2 31-1/4 - A10-3	30	7/8 1 1-1/4 1-1/4	10	1-5/8 x 2-5/8 1-5/8 x 2-5/8 1-5/8 x 2-5/8 1-7/8 x 3-1/8	1	7010005 7010010 7010015 7010017	
40-7/8 - A10 40-7/8 - A16-3	40	7/8	10 16	- 1-7/8 x 3-1/8	- 1	7010020 9110025	
41 - A8 41 - A10 41 - A12 41 - A16-3	40	1	8 10 12 16	- - - 1-7/8 x 3-1/8	- - - 1	7010027 7010028 9910030 9910035	
41-1/4 - A8 41-1/4 - A10 41-1/4 - A12 41-1/4 - A16-3	40	1-1/4	8 10 12 16	- - - 1-7/8 x 3-1/8	- - - 1	7010037 7010038 9910040 9910045	
50-7/8 - A10 50-7/8 - A18-4	50	7/8	10 18	- 2-1/8 x 3-3/4	- 1	9210050 9110055	
51 - A8 51 - A12 51 - A18-4	50	1	8 12 18	- - 2-1/8 x 3-3/4	- - 1	7010057 9910060 9910065	
51-1/4 - A8 51-1/4 - A12 51-1/4 - A18-4	50	1-1/4	8 12 18	- - 2-1/8 x 3-3/4	- - 1	7010067 9910070 9910075	

## STYLE B

31 - B1	30	1	1	-	-	7015001	
31 - B2	30	1	2	-	-	7015002	
40-7/8 - B14-3 40-7/8 - B16-3	40	7/8	14 16	1-7/8 x 3-1/8	1	7015005 7015006	
41 - B3 41 - B14-3 41 - B20-3	40	1	3 14 20	- 1-7/8 x 3-1/8 1-7/8 x 3-1/8	- 1 1	7015008 7015010 7015015	
41-1/4 - B3 41-1/4 - B14-3 41-1/4 - B20-3 41-1/2 - B20-4	40	1-1/4	3 14 20 20	- 1-7/8 x 3-1/8 1-7/8 x 3-1/8 2-1/8 x 3-3/4	- 1 1 1	7015017 7015020 7015025 7015030	
51 - B3-1/2 51 - B15-4 51 - B18-4 51 - B24-4	50	1	3-1/2 15 18 24	- 2-1/8 x 3-3/4 2-1/8 x 3-3/4 2-1/8 x 3-3/4	- 1 2 2	7015033 7015035 7015040 7015045	
51-1/4 - B3-1/2 51-1/4 - B15-4 51-1/4 - B18-4 51-1/4 - B24-4 51-1/4 - B30-4	50	1-1/4	3-1/2 15 18 24 30	- 2-1/8 x 3-3/4 2-1/8 x 3-3/4 2-1/8 x 3-3/4 2-1/8 x 3-3/4	- 1 2 2 2	7015047 7015050 7015055 7015060 7015065	
51-1/2 - B3-1/2 51-1/2 - B18-4 51-1/2 - B24-5 51-1/2 - B30-5 51-1/2 - B36-5	50	1-1/2	3-1/2 18 24 30 36	- 2-1/8 x 3-3/4 2-3/4 x 4-1/4 2-3/4 x 4-1/4 2-3/4x 4-1/4	- 2 2 2 2	7015067 7015070 7015075 7015080 7015085	
52 - B24-5 52 - B30-5 52 - B36-5	50	2	24 30 36	2-3/4 x 4-1/4	2	7015090 7015095 7015100	
52-1/2 - B36-6	50	2-1/2	36	3-3/8 x 4-1/4	2	7015105	

# SOLID SPACERS WITH KEYWAYS

## SERIES 361:

Spacers are hardened and have parallel and perpendicular surfaces precisely ground to ensure precise operation of cutters on milling machine arbors.



Width of Spacer	7/8" hole 1-3/8" O.D.		1" hole 1-1/2" O.D.		1-1/4" hole 1-3/4" O.D.		1-1/2" hole 2-1/8" O.D.		2" hole 2-3/4" O.D.		2-1/2" hole 3-1/4" O.D.	
	Order No.	Price	Order No.	Price	Order No.	Price	Order No.	Price	Order No.	Price	Order No.	Price
1/16	7020005		7020090		7020175		7020260		7020385		7020470	
3/32	7020010		7020095		7020180		7020265		7020390		7020475	
1/8	7020015		7020100		7020185		7020270		7020395		7020480	
3/16	7020020		7020105		7020190		7020275		7020400		7020485	
1/4	7020025		7020110		7020195		7020280		7020405		7020490	
5/16	7020030		7020115		7020200		7020285		7020410		7020495	
3/8	7020035		7020120		7020205		7020290		7020415		7020500	
7/16	7020040		7020125		7020210		7020295		7020420		7020505	
1/2	7020045		7020130		7020215		7020300		7020425		7020510	
5/8	7020050		7020135		7020220		7020305		7020430		7020515	
3/4	7020055		7020140		7020225		7020310		7020435		7020520	
7/8	7020060		7020145		7020230		7020315		7020440		7020525	
1	7020065		7020150		7020235		7020320		7020445		7020530	
1-1/4	7020070		7020155		7020240		7020325		7020450		7020535	
1-1/2	7020075		7020160		7020245		7020330		7020455		7020540	
2	7020080		7020165		7020250		7020335		7020460		7020545	
3	7020085		7020170		7020255		7020340		7020465		7020550	
<b>Width of Keyway</b>	1/8		1/4		5/16		3/8		1/2		5/8	

# ARBOR RUNNING BUSHINGS

## SERIES 362:

Bushings are hardened and have parallel and perpendicular surfaces precisely ground to ensure maximum holding power, rigid setup and accurate machining operations. Bushings have standard keyways which allow fixed mounting on arbor and prevent rotation.



# ARBOR SPACER SHIM SETS

## SERIES 671:



With standard keyways.

19 pc. assortments consists of one shim each of the following thicknesses:  
.001, .0015, .002, .003, .004, .005, .006, .007, .008, .010, .012, .015, .020, .025, .031, .047, .062, .093, .125.

O.D. of Bushing	Diameter of Hole	Length of Bushing	Width of Keyway	Order No.	Price
1-5/8	7/8	2-5/8	1/8	7025005	
1-5/8	1	2-5/8	1/4	7025010	
1-5/8	1-1/4	2-5/8	5/16	7025015	
1-7/8	7/8	3-1/8	1/8	7025020	
1-7/8	1	3-1/8	1/4	7025025	
1-7/8	1-1/4	3-1/8	5/16	7025030	
2-1/8	7/8	3-3/4	1/8	7025035	
2-1/8	1	3-3/4	1/4	7025040	
2-1/8	1-1/4	3-3/4	5/16	7025045	
2-1/8	1-1/2	3-3/4	3/8	7025050	
2-3/4	7/8	4-1/4	1/8	7025055	
2-3/4	1	4-1/4	1/4	7025060	
2-3/4	1-1/4	4-1/4	5/16	7025065	
2-3/4	1-1/2	4-1/4	3/8	7025070	
2-3/4	2	4-1/4	1/2	7025075	
3-3/8	2-1/2	4-1/2	5/8	7025080	

Inside Dia.	Outside Dia.	Order No.	Price
7/8	1-3/8	6714200	
1	1-1/2	6714220	
1-1/4	1-3/4	6714260	
1-1/2	2-1/8	6714460	
2	2-3/4	6714480	

## END MILL HOLDERS WITH "R-8" TAPER SERIES 371



- Made of alloy forged steel for long, durable service life.
- Hardened to RC 56-60 and ground to ensure maximum accuracy.
- End Mill Socket T.I.R. <0.0004".

For holding single and double end end mills.

Model No.	Hole Dia.	MEDA		BISON	
		Order No.	Price	Order No.	Price
ER8-3/16	3/16	2150000		7160005	
ER8-3/8	3/8	2150001		7160010	
ER8-1/2	1/2	2150002		7160015	
ER8-5/8*	5/8	2150003		7160020	
ER8-3/4*	3/4	2150004		7160025	
ER8-7/8*	7/8	2150005		7160030	
ER8-1*	1	2150006		7160035	
ER8-1-1/4*	1-1/4	2150007		7160040	
ER8-1-1/2*	1-1/2	2150008		7160045	

\* For Single-end End Mills only.

### SETS



MEDA set supplied in wooden stand.  
BISON sets supplied in wooden case.

Brand	Pieces Per Set	Range	Order No.	Price
MEDA	6	3/16 - 3/4" + 1"	2150500	
BISON	5	3/16 - 3/4"	7160105	
BISON	8	3/16 - 1 1/4"	7160108	

## SLITTING SAW & STUB MILLING MACHINE ARBOR WITH R8 SHANK



### SERIES 363:

- Made of alloy forged steel for long, durable service life.
- Hardened to RC 56-60 and ground to ensure maximum accuracy.
- Face is held perpendicular to center line within 0.0004".
- Pilot diameter is sized for precision fit with cutter and is keyed for positive drive.
- Heavy duty locking RH nut and three arbor spacers are included.



Shank Dia.	Arbor Dia. d	L	MEDA		BISON	
			Order No.	Price	Order No.	Price
R8	1	2	2110010		7070005	
R8	1-1/4	2	2110020		7070010	

## STUB MILLING MACHINE ARBORS, WELDON SHANK

### SERIES 363:

- For holding saws or small cutters.
- Designed to fit directly into standard end mill adapters.
- Made of alloy forged steel for long, durable service life.
- Hardened to RC 56-60 and ground to ensure maximum accuracy.
- Face is held perpendicular to center line within 0.0004".
- Pilot diameter is sized for precision fit with cutter and is keyed for positive drive.
- Heavy duty locking LH nut and three arbor spacers are included.

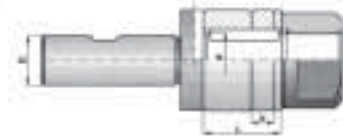

Shank Dia.	Arbor Dia. d	L	MEDA		BISON	
			Order No.	Price	Order No.	Price
1/2	1/2	1	3633232		7072005	
	5/8		3633240		7072010	
	3/4		3633248		7072015	
3/4	1/2	1	3634832		7072020	
	5/8		3634840		7072025	
	3/4		3634848		7072030	
	7/8		3634856		7072035	
	1		3634864		7072040	
	1-1/4		3634880		7072045	

Quality Machine  
Tool Accessories



The Choice Is Yours!!!

## END MILL HOLDERS WITH MORSE TAPER SHANK



**SERIES 369 : STYLE "A" WITH TANG END**  
**SERIES 370 : STYLE "B" WITH THREADED END FOR DRAWBAR**

- Made of alloy forged steel for long, durable service life.
- Hardened to RC 56-60 and ground to ensure maximum accuracy.
- End Mill Socket T.I.R. <0.0004".
- Sets are provided with nice wooden case.



Style A - "Tang Style"



Style B - "Drawbar Style"

For holding single and double end end mills.

\* For single-end mills only.

Model No.	Taper	Hole Diameter	Order No.		Price
			Style "A"	Style "B"	
MT2-3/16	M.T.2	3/16	2140040	2145040	
MT2-3/8	M.T.2	3/8	2140041	2145041	
MT2-1/2*	M.T.2	1/2	2140042	2145042	
MT2-5/8*	M.T.2	5/8	2140043	2145043	
MT3-3/16	M.T.3	3/16	2140050	2145050	
MT3-3/8	M.T.3	3/8	2140051	2145051	
MT3-1/2	M.T.3	1/2	2140052	2145052	
MT3-5/8*	M.T.3	5/8	2140053	2145053	
MT3-3/4*	M.T.3	3/4	2140054	2145054	
MT4-3/8	M.T.4	3/8	2140061	2145061	
MT4-1/2	M.T.4	1/2	2140062	2145062	
MT4-5/8	M.T.4	5/8	2140063	2145063	
MT4-3/4	M.T.4	3/4	2140064	2145064	
MT4-7/8*	M.T.4	7/8	2140065	2145065	
MT4-1*	M.T.4	1	2140066	2145066	
MT5-3/8	M.T.5	3/8	2140071	2145071	
MT5-1/2	M.T.5	1/2	2140072	2145072	
MT5-5/8	M.T.5	5/8	2140073	2145073	
MT5-3/4	M.T.5	3/4	2140074	2145074	
MT5-7/8	M.T.5	7/8	2140075	2145075	
MT5-1	M.T.5	1	2140076	2145076	
MT5-1-1/4*	M.T.5	1-1/4	2140077	2145077	
MT5-1-1/2*	M.T.5	1-1/2	2140078	-	
MT5-2*	M.T.5	2	2140079	-	
MT6-1-1/4*	M.T.6	1-1/4	2140081	-	
MT6-1-1/2*	M.T.6	1-1/2	2140082	-	
MT6-2*	M.T.6	2	2140083	-	

**SETS: Style "A"** Supplied in wooden case.

Shank	Pcs. Per Set	Range	Order No.	Price
MT2	5	3/16 - 5/8"	7155302	
MT3	6	3/16 - 3/4"	7155303	
MT4	5	3/16 - 7/8"	7155304	
MT5	9	3/8 - 2"	7155305	



## SHELL END MILL ARBORS WITH "R-8" TAPER



**SERIES 374:**



- Made of alloy forged steel for long, durable service life.
- Hardened to RC 56-60 and ground to ensure maximum accuracy.
- Shell End Mill Pilot T.I.R. <0.0004".

Hole Dia.	Range of Shell E/M	MEDA		BISON	
		Order No.	Price	Order No.	Price
1/2	1-1/4 to 1-1/2	2165002		7065005	
3/4	1-3/4 to 2	2165004		7065010	
1	2-1/4 to 2-3/4	2165006		7065015	
1-1/4	3 to 3-1/2	2165007		7065020	
1-1/2	4 to 5	2165008		7065025	

**SETS:**



MEDA set supplied in wooden holder.

BISON set supplied in wooden case.

Description	MEDA		BISON	
	Order No.	Price	Order No.	Price
5 Pc. Set 1/2 - 1 1/2"	2165005		7065805	

## SHELL END MILL ARBORS WITH STRAIGHT SHANK



**SERIES 375:**



Dia. of Shank	Dia. for Shell End Mill Hole	Order No.	Price
1/2	1/2	2170023	
1/2	3/4	2170024	
3/4	3/4	2170044	
3/4	1	2170046	

## ARBOR SCREWS FOR SHELL END MILL ARBORS

**SERIES 379:**



Arbor Dia. Size	Thread	Order No.	Price
1/2	1/4-28	7080005	
3/4	3/8-24	7080010	
1	1/2-20	7080015	
1-1/4	5/8-18	7080020	
1-1/2	3/4-16	7080025	
2	1-14	7080030	

# END MILL HOLDERS WITH NST 30, 40 & 50 TAPERS



## SERIES 364:

NST Taper	Hole Dia.	MEDA		BISON		BISON (Sets)	
		Order No.	Price	Order No.	Price	Order No.	Price
30	3/16	2115100		7165005		7165307 8 Pc. Set	
	1/4	-		7165007			
	3/8	2115110		7165010			
	1/2	2115120		7165015			
	5/8	2115130		7165020			
	3/4	2115140		7165025			
	7/8	2115150		7165026			
	1	2115160		7165027			
40	3/16	2115200		7165030		7165409 10 Pc. Set	
	1/4	-		7165032			
	3/8	2115210		7165035			
	1/2	2115220		7165040			
	5/8	2115230		7165045			
	3/4	2115240		7165050			
	7/8	2115250		7165055			
	1	2115260		7165060			
	1-1/4*	2115270		7165065			
	1-1/2*	2115280		7165070			
50	3/16	-		7165073		7165510 10 Pc. Set	
	3/8	2115310		7165075			
	1/2	2115320		7165080			
	5/8	2115330		7165085			
	3/4	2115340		7165090			
	7/8	2115350		7165095			
	1	2115360		7165100			
	1-1/4*	2115370		7165105			
	1-1/2*	2115380		7165110			
	2*	2115390		7165115			
	2-1/2*	2115400		-			

- Produced according to AT3 specifications.
- Made of alloy forged steel for long, durable service life.
- Hardened to RC 56-60 and ground to ensure maximum accuracy.
- End Mill Socket T.I.R. <0.0004".



### Draw Bar Threads:

NST 30 1/2" - 13  
 NST 40 5/8" - 11  
 NST 50 1" - 8

\*Holders are only for single end mills

## SHELL END MILL ARBORS WITH MT SHANK

### SERIES 376:



- Made of alloy forged steel for long, durable service life.
- Hardened to RC 56-60 and ground to ensure maximum accuracy.
- Shell End Mill Pilot T.I.R. <0.0004".



Style A - "Tang Style"



Style B - "Drawbar Style"

### Draw Bar Threads:

MT 4 1/2" - 13  
 MT 5 5/8" - 11

MT Shank	Arbor Dia.	For Shell End Mills	Style "A"		Style "B"	
			Order No.	Price	Order No.	Price
4	1/2	1-1/4 to 1-1/2	7051005		7055005	
	3/4	1-3/4 to 2	7051010		7055010	
	1	2-1/4 to 2-3/4	7050015		7055015	
	1-1/4	3 to 3-1/2	7051020		7055020	
	1-1/2	4 to 5	7051025		7055025	
5	1	2-1/4 to 2-3/4	7050030		7055030	
	1-1/4	3 to 3-1/2	7050035		7055035	
	1-1/2	4 to 5	7050040		7055040	

## FACE MILL HOLDERS

### SERIES 204:



- NST Taper is produced according to AT3 specifications.
- Made of alloy forged steel for long, durable service life.
- Shell Mill Pilot T.I.R. <0.0004".
- Holders have four mounting holes with the thread 5/8 - 11 on a 4" bolt circle to hold 8" or larger Face Milling Cutters.
- Holders have 1" Drive Keys.



### Draw Bar Threads:

NST 40 5/8" - 11  
 NST 50 1" - 8  
 NST 60 1-1/4" - 7

Shank	Holder Dia.	Arbor Length	Order No.	Price
NST 40	2	6.20	7170005	
	2-1/2		7170020	
NST 50	2	7.56	7170010	
	2-1/2		7170025	
NST 60	2	10.70	7170015	
	2-1/2		7170030	

Shank	Holder Dia.	Arbor Length	Order No.	Price
MT 5	2	9.57	7170035	
	2-1/2		7170045	
MT 6	2	13.58	7170040	
	2-1/2		7170050	

# SHELL END MILL ARBORS WITH NST SHANK

## SERIES 373:



**Draw Bar Threads:**  
 NST 30 1/2" - 13  
 NST 40 5/8" - 11  
 NST 50 1"-8

NST Shank	Arbor Dia.	For Shell End Mills	Order No.	Price
30	1/2	1-1/4 to 1-1/2	7060005	
	3/4	1-3/4 to 2	7061010	
	1	2-1/4 to 2-3/4	7060015	
	1-1/4	3 to 3-1/2	7061020	
40	1/2	1-1/4 to 1-1/2	7060025	
	3/4	1-3/4 to 2	7060030	
	1	2-1/4 to 2-3/4	7060035	
	1-1/4	3 to 3-1/2	7060040	
	1-1/2	4 to 5	7060045	
	2	5-1/2 to 6	7060050	
50	1/2	1-1/4 to 1-1/2	7060055	
	3/4	1-3/4 to 2	7060060	
	1	2-1/4 to 2-3/4	7060065	
	1-1/4	3 to 3-1/2	7060070	
	1-1/2	4 to 5	7060075	
	2	5-1/2 to 6	7060080	
	2-1/2	6-1/2 & larger	2170040	



## 4" EXTENSION TYPE

### SERIES 373:



- Made of alloy forged steel for long, durable service life.
- Hardened to RC 56-60 and ground to ensure maximum accuracy.
- Shell End Mill Pilot T.I.R. <0.0004".
- Sets in wooden case available; please inquire.

NST Shank	Arbor Dia.	For Shell End Mills	Order No.	Price
40	3/4	1-3/4 to 2	7075002	
	1	2-1/4 to 2-3/4	7075005	
50	1	2-1/4 to 2-3/4	7075010	
	1-1/4	3 to 3-1/2	7075015	
	1-1/2	4 to 5	7075020	

# MILLING MACHINE ADAPTERS

## SERIES 365:



### FOR CHANGING FROM NST SHANK TO R8 SOCKET

### FOR CHANGING FROM ONE NST TAPER TO A SMALLER NST

- NST Shanks are produced according to AT3 specifications.
- Made of alloy forged steel for long, durable service life.
- Hardened to RC 56-60 and ground to ensure maximum accuracy.
- Taper seat T.I.R. <0.0004".



#### Open End Type

NST Shank	NST Hole	Order No.	Price
40	30	7110005	
50	30	7110010	
50	40	7110015	



Adapters are provided with the screw (inside) to hold tools with 7/16-20 R8 shank. To hold adapter in the spindle use draw bar with standard thread.

#### Drawbar End Type

NST Shank	Hole	Draw Bar Thread	Order No.	Price
40	R8	5/8-11	7105005	
50	R8	1 - 8	7105010	

### FOR CHANGING FROM NST SHANK TO MT SOCKET



#### Drawbar End Type

NST Shank	MT Hole	Draw Bar Thread	Order No.	Price
40	2	5/8 - 11	7120005	
	3		7140010	
	4		7100015	
	5		7140020	
	5		7100024	
50	2	1-8	7110025	
	3		7100030	
	4		7100035	
	5		7100035	

### FOR CHANGING FROM NST SHANK TO MT SOCKET

#### Open End Type

NST Shank	MT Hole	Order No.	Price
40	2	7090005	
	3	7090010	
	4	7090015	
50	3	7190020	
	4	7090025	
	5	7090030	



### FOR CHANGING FROM R8 SHANK TO MT SOCKET



#### Drawbar End Type

R8 Shank	MT Hole	Draw Bar Thread	MEDA		BISON	
			Order No.	Price	Order No.	Price
R8 R8	2	7/16 - 20	2125004		7115005	
	3	7/16 - 20	2125005		7115010	



# SLITTING OR SLOTTING SAW ARBORS



SERIES 382



Spring loaded mechanism on Order No.'s 2205000 and 2205002 permits use of saw blades with various hole diameters.

Diameter of Arbor	Length	Fits Hole Sizes	Order No.	Price
1/2 R-8	2-1/2 5-3/32	1/2-1 x 8ths	2205000 2205002	
1/2	2-3/4	1/4	2205016	
1/2	2-1/2	3/8	2205024	
1/2	2-1/2	1/2	2205032	
<b>3-Piece Set On A Wooden Block Includes: 2205016, 2205024, 2205032</b>				
1/2	2-1/2	1/4,3/8,1/2	2205300	



While we show the most popular **BISON** items, we can supply their entire range of products; please inquire.



# SLITTING & SLOTTING SAW ARBORS



SERIES 382:

## HARDENED AND PRECISELY GROUND

- Rigid arbors, with extended length, reach areas that standard short arbors cannot.
- Each arbor is ground for precision within 0.002".
- Super low profile cups allows cutter to get lower and closer to working area.
- Plug style cup gives extra support and rigidity when working with larger diameter saws.
- Sets are supplied in a wooden stand.

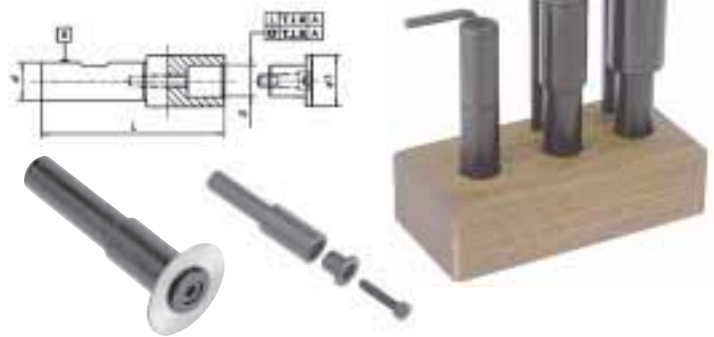

Shank Dia. d	T.I.R. Hole Size D	d <sub>1</sub>	L	Order No.	Price
.500	.250	.500	2.70	7123005	
	.375	.625	2.88	7123010	
	.500	.750	3.07	7123015	
Set of 3 Arbors .250" - .500"				7123050	
.750	.625	1.00	3.53	7123105	
	1.000	1.50	3.78	7123110	
	1.250	1.75	4.03	7123115	
Set of 3 Arbors .625" - 1.250"				7123150	

# UNIVERSAL CNC TOOL TIGHTENING FIXTURES

SERIES 639:

## FEATURES:

- Multiple usage on tool holder tapers NMTB (ISO), CAT & BT as well as cylindrical tooling.
- Efficiently designed for maximum protection of tool holder.
- Enables strong gripping power of cutting tools.
- Compact design for mounting on work table or tool cart.
- Fixture No. 7189543 comes complete with 4 pc. set of inter-changeable adapters to cover tapers 30, 40 & 50.



Taper Size	H	K	L	d	Weight lbs.	Order No.	Price
40		3.0	6.7	1.69	12.5	7189400	
50	8.0	4.5	10.0	2.00	31.0	7189500	
30, 40, & 50		4.5	9.5	2.83	36.0	7189543	

# INTERCHANGEABLE ADAPTERS FOR TAPERS #30 & 40 - FOR USE WITH ORDER NO. 7189500

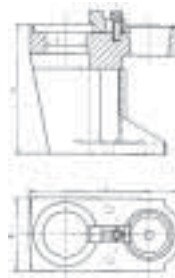

	Adapters for Taper NST 30
	Adapters for Taper NST 40

Adapter No.	Shank Size	Adapter Order No.	Price
1*	30	7189581	
2**	30	7189583	
3	40	7189593	
4	40	7189594	

\*1" Cylindrical  
\*\*2" Cylindrical



# CATERPILLAR V-FLANGE TG COLLET CHUCKS

**COMPLETELY INTERCHANGEABLE WITH ALL TG-100 & 150 COLLETS**

**SERIES 654:**

- \* Completely Interchangeable with all TG Collets.
- \* Produced according to AT3 specifications.
- \* Collet seat taper T.I.R. < .0002".
- \* Made of alloy forged steel for long, durable service life.
- \* Hardened to RC 52-56 and ground to ensure maximum accuracy.
- \* Through spindle coolant capability.
- \* Retention Knobs are sold separately.

**Draw Bar Threads:**  
**CAT-40** 5/8" - 11  
**CAT-50** 1" - 8



**Collet Wrench**

Taper No.	TG Collet No.	Collet Clamping Range	d	L <sub>1</sub>	L	Chuck Order No.	Price
40	100	3/32-1	2-1/2	3	5-11/16	7180403	
				4	6-11/16	7180404	
				6	8-11/16	7180406	
50	100	3/32-1	2-1/2	3-1/8	7-1/8	7180503	
				3-1/2	7-1/2	7180504	
				5-1/2	9-1/8	7180505	
				7-1/2	11-1/2	7180507	
				3	7	7180513	
	150	1/2-1-1/2	3-1/2	3-1/2	7-1/2	7-1/2	7180514
					9-1/2	9-1/2	7180517
					11-1/2	11-1/2	7180518

TG Collet Style	Wrench Order No.	Price
100	7180930	
150	7180935	

## 100 TG COLLETS

**SERIES 661:**



## 150 TG COLLETS

**SERIES 662:**



Size	Order No.	Price	Size	Order No.	Price
3/32	6610006		37/64	6610037	
7/64	6610007		19/32	6610038	
1/8	6610008		39/64	6610039	
9/64	6610009		5/8	6610040	
5/32	6610010		41/64	6610041	
11/64	6610011		21/32	6610042	
3/16	6610012		43/64	6610043	
13/64	6610013		11/16	6610044	
7/32	6610014		45/64	6610045	
15/64	6610015		23/32	6610046	
1/4	6610016		47/64	6610047	
17/64	6610017		3/4	6610048	
9/32	6610018		49/64	6610049	
19/64	6610019		25/32	6610050	
5/16	6610020		51/64	6610051	
21/64	6610021		13/16	6610052	
11/32	6610022		53/64	6610053	
23/64	6610023		27/32	6610054	
3/8	6610024		55/64	6610055	
25/64	6610025		7/8	6610056	
13/32	6610026		57/64	6610057	
27/64	6610027		29/32	6610058	
7/16	6610028		59/64	6610059	
29/64	6610029		15/16	6610060	
15/32	6610030		61/64	6610061	
31/64	6610031		31/32	6610062	
1/2	6610032		63/64	6610063	
33/64	6610033		1	6610064	
17/32	6610034				
35/64	6610035				
9/16	6610036				

Size	Order No.	Price	Size	Order No.	Price
1/2	6620032		1	6620064	
33/64	6620033		1-1/64	6620065	
17/32	6620034		1-1/32	6620066	
35/64	6620035		1-3/64	6620067	
9/16	6620036		1-1/16	6620068	
37/64	6620037		1-5/64	6620069	
19/32	6620038		1-3/32	6620070	
39/64	6620039		1-7/64	6620071	
5/8	6620040		1-1/8	6620072	
41/64	6620041		1-9/64	6620073	
21/32	6620042		1-5/32	6620074	
43/64	6620043		1-11/64	6620075	
11/16	6620044		1-3/16	6620076	
45/64	6620045		1-13/64	6620077	
23/32	6620046		1-7/32	6620078	
47/64	6620047		1-15/64	6620079	
3/4	6620048		1-1/4	6620080	
49/64	6620049		1-17/64	6620081	
25/32	6620050		1-9/32	6620082	
51/64	6620051		1-19/64	6620083	
13/16	6620052		1-5/16	6620084	
53/64	6620053		1-21/64	6620085	
27/32	6620054		1-11/32	6620086	
55/64	6620055		1-23/64	6620087	
7/8	6620056		1-3/8	6620088	
57/64	6620057		1-25/64	6620089	
29/32	6620058		1-13/32	6620090	
59/64	6620059		1-27/64	6620091	
15/16	6620060		1-7/16	6620092	
61/64	6620061		1-29/64	6620093	
31/32	6620062		1-15/32	6620094	
63/64	6620063		1-31/64	6620095	
			1-1/2	6620096	

# CATERPILLAR V-FLANGE END MILL HOLDERS

SERIES 655:



MACHINE TOOL ACCESSORIES

Taper No.	D	L <sub>1</sub>	L	L <sub>3</sub>	L <sub>2</sub>	D <sub>1</sub>	Holder Order No.	Price
40	3/16	2-1/2	5-3/16	9/16	-	3/4	7185411	
	1/4	2-1/2	5-3/16		-	13/16	1854113	
	1/4	4	6-11/16		-	13/16	1854114	
	5/16	2-1/2	5-3/16	25/32	-	7/8	1854115	
	5/16	4	6-11/16		-	7/8	1854117	
	3/8	2-1/2	5-3/16		-	1-3/8	7185412	
	3/8	5	7-11/16		-	1-3/8	1854122	
	7/16	2-1/2	5-3/16		-	1-1/4	1854123	
	1/2	2-5/8	5-5/16	7/8	-	1-3/4	7185413	
	1/2	5	7-11/16		-	1-3/4	7185417	
	5/8	3-3/4	6-7/16	15/16	-	1-3/4	7185431	
	5/8	5-1/2	8-3/16	15/16	-	1-3/4	7185437	
	3/4	3-3/4	6-7/16	1	-	1-3/4	7185441	
	3/4	5-1/2	8-3/16	1	-	1-3/4	7185447	
	7/8	4	6-11/16	1-1/16	7/8	2-3/64	7185451	
	1	4	6-11/16			2-31/64	7185461	
	1-1/4	4-1/8	6-15/16			2-3/4	7185471	
	1-1/4	6	8-11/16	1-1/8	1	2-3/4	7185475	
	1-1/2	4-5/8	7-5/16			3-9/64	7185481	
	1-1/2	6	8-11/16			3-9/64	7185485	
50	4-1/2	8-1/2	25/32	-	1-1/4	7185512		
	3/8	6-1/2	10-1/2			7185513		
		2-5/8	6-5/8		-		7185521	
	1/2	4-5/8	8-5/8	7/8	-	1-3/4	7185522	
		6-5/8	10-5/8		-		7185523	
	5/8	3-3/4	7-3/4		-		7185531	
		5-3/4	9-3/4	15/16	-	1-3/4	7185532	
		7-3/4	11-3/4		-		7185533	
	3/4	3-3/4	7-3/4		-		7185541	
		5-3/4	9-3/4	1	-	1-3/4	7185542	
		7-3/4	11-3/4		-		7185543	
	7/8	3-3/4	7-3/4				7185551	
		5-3/4	9-3/4	1-1/16	7/8	2-3/64	7185552	
		7-3/4	11-3/4				7185553	
	1	4	8				7185561	
		6	10	1-1/8	1	2-31/64	7185562	
		8	12				7185563	
	1-1/4	4	8				7185571	
	6	10	1-1/8	1	2-3/4	7185572		
	8	12				7185573		
1-1/2	4	8				7185581		
	6	10	1-1/8	1	3-9/64	7185582		
	8	12				7185583		
2	5-5/8	9-5/8				7185591		
	7-5/8	11-5/8	1-3/16	1-7/16	3-15/16	7185592		
	9-5/8	13-5/8				7185593		
2-1/2	6	10	1-3/16	1-7/16	4-1/4	7185595		

**DRAW BAR THREADS:**  
**CAT-40** 5/8" - 11  
**CAT-50** 1" - 8

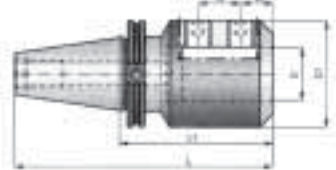

- Produced according to AT3 specifications.
- Made of alloy forged steel for long, durable service life.
- Hardened to RC 52-56 and ground to ensure maximum accuracy.
- End Mill Socket T.I.R. <0.0002".
- Through spindle coolant capability.
- Retention Knobs are sold separately.

## CNC AND COLLET PLATFORM

SERIES 569:

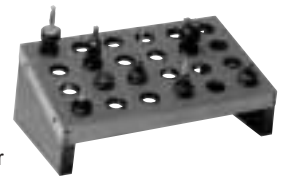

Conveniently holds your CNC toolholders or collets at the ready, for quick access. Angled platform for the 30-35-40-45-50 taper tools and 5C or R8 collets. Holds 24 toolholders for 30-35 and 40 taper, 18 tools for 45 and 50 taper, and 96 tools for 5C or R8.

Model No.	Order No.	Price
30P	14830	
35P	14835	
40P	14840	
45P	14845	
50P	14850	
96P5C	14856	
96PR8	9914866	

See additional CNC holders on page 601.

# CATERPILLAR V-FLANGE FACE MILL HOLDERS

SERIES 656:

- Produced according to AT3 specifications.
- Made of alloy forged steel for long, durable service life.
- Shell Mill Pilot T.I.R. <0.0002".
- Holders have four mounting holes with 5/8 - 11 thread on a 4" bolt circle to hold 8" or larger Face Milling Cutters.
- Retention Knobs are sold separately.

**Draw Bar Threads:**  
**CAT - 40** 5/8" - 11  
**CAT - 50** 1" - 8



Taper No.	Arbor Dia. D2	L <sub>1</sub>	L <sub>2</sub>	L <sub>3</sub>	Drive Key L <sub>4</sub>	D <sub>1</sub>	Holder Order No.	Price
50	2	7.3	2.4	15/16	3/4	4-7/8	7182502	
	2	8.9	4	15/16	3/4	4-7/8	7182504	
	2-1/2	7.5	2.4	1-1/8	1	4-7/8	7182512	
	2-1/2	9.1	4	1-1/8	1	4-7/8	7182514	

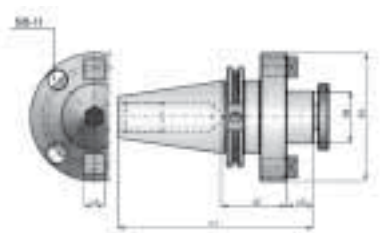

## CATERPILLAR V-FLANGE ER COLLET CHUCKS AND SETS

**SERIES 664:**



- Produced according to AT3 specifications.
- Collet seat taper T.I.R. < .0002".
- Made of alloy forged steel for long, durable service life.
- Hardened to RC 52-56 and ground to ensure maximum accuracy.
- Through spindle coolant capability.
- Retention Knobs are sold separately.

See page 587 for Collet Nuts and Wrenches

More chuck lengths & more sets available; please inquire.

17 pc. ER Collet Chuck Sets

Sets include 15 collets 1/8-1x16<sup>th</sup>, collet chuck and wrench in case.

Draw Bar Threads:  
CAT-40 5/8" - 11  
CAT-50 1" - 8

Taper No.	ER Collet No.	Collet Clamping Range	d	L <sub>1</sub>	L	Chuck Order No.	Price
40	ER16	1/8-7/16	1.26	2.5	5.20	7188415	
				3	5.70	7188417	
	ER20	1/8-1/2	1.38	2.5	3.4	7188420	
				4	3.6	7188422	
	ER25	1/8-5/8	1.65	2.5	5.2	7188424	
				4	6.70	7188426	
	ER32	1/8-3/4	1.97	3	5.70	7188431	
				4	6.70	7188432	
	ER40	1/8-1	2.50	4	6.70	7188440	
				17 pc. Set	7188449		
50	ER40	1/8-1	2.50	4	8.00	7188540	
				17 pc. Set	7188549		

See pages 584 - 587 for collets.

## CATERPILLAR V-FLANGE ADAPTERS, CAT-50 TO 40

**SERIES 657:**



- Produced according to AT3 specifications.
- Made of alloy forged steel for long, durable service life.
- Taper seat T.I.R. < 0.0002".
- Retention Knobs are sold separately.

Draw Bar Threads:  
CAT40 5/8" 11  
CAT50 1" 8

Taper No.	Taper No. Hole	L	D	d	Weight lbs.	Order No.	Price
50	40	3.150	3.46	.65	6.6	7184504	

## CATERPILLAR V-FLANGE DOUBLE ANGLE COLLET CHUCKS

**SERIES 654:**



- Suitable for use with all DA180 Collets.
- Produced according to AT3 specifications.
- Collet seat taper T.I.R. < .0002".
- Made of alloy forged steel for long, durable service life.
- Hardened to RC 52-56 and ground to ensure maximum accuracy.
- Through spindle coolant capability.
- Retention Knobs are sold separately.

Draw Bar Threads:  
CAT-40 5/8" - 11  
CAT-50 1" - 8



DA180 Collets

Taper No.	Collet Range	L	D Hex	Chuck Order No.	Price
CT 40	1/8-3/4	2.75	1.54	7193415	
		4		7193424	
CT 50	1/8-3/4	4	1.54	7193524	
		6		7193526	
		8		7193528	

See page 583 for collets.

## CATERPILLAR V-FLANGE MT ADAPTERS

**SERIES 657:**



- Produced according to AT3 specifications.
- Made of alloy forged steel for long, durable service life.
- Morse Taper Seat T.I.R. < 0.0002".
- Hardened to RC 52-56 and ground to ensure maximum accuracy.
- Retention Knobs are sold separately.

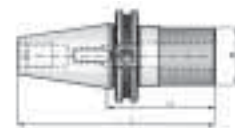

Draw Bar Threads:  
CAT-40 5/8" - 11  
CAT-50 1" - 8

Taper No.	MT Hole	D	L	L <sub>1</sub>	Order No.	Price
40	2	1-1/4	4-7/8	2-3/16	7183402	
	3	1-3/4	5-7/16	2-3/4	7183403	
	4	2	6-1/4	3-9/16	7183404	
50	2	1-1/4	6	2	7183502	
	3	1-5/8	6-1/2	2-1/2	7183503	
	4	2	7-3/8	3-3/8	7183504	
	5	2-3/4	7-3/4	3-3/4	7183505	

## CATERPILLAR V-FLANGE SHELL END MILL HOLDERS

**SERIES 656:**

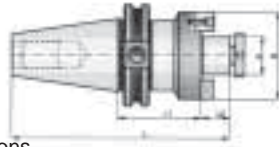

- Produced according to AT3 specifications.
- Alloy forged steel for long, durable service life.
- Hardened to RC 52-56 and ground to ensure maximum accuracy.
- Shell Mill Pilot T.I.R. < 0.0002".
- Retention knobs are sold separately.

**Draw Bar Threads:**  
**CAT-40** 5/8" - 11  
**CAT-50** 1" - 8

Taper No.	d	L <sub>1</sub>	L	L <sub>2</sub>	D <sub>2</sub>	Holder Order No.	Price
40	1/2	1-3/8	4-5/8	9/16	1-3/8	7186403	
	3/4	1-3/8	4-3/4	11/16	1-49/64	7186405	
	1	2-1/16	5-7/16	11/16	2-11/64	7186407	
	1-1/4	2-1/8	5-1/2	11/16	2-33/64	7186409	
	1-1/2	2-13/16	6-1/32	15/16	3-5/64	7186411	
50	1/2	1-1/2	6-3/16	9/16	1-3/8	7186503	
		3-1/2	8-3/16			7186505	
		5-1/2	10-3/16			7186507	
	3/4	1-1/2	6-3/16	11/16	1-49/64	7186509	
		3-1/2	8-3/16			7186511	
		5-1/2	10-3/16			7186513	
	1	2	6-11/16	11/16	2-11/64	7186515	
		4	8-11/16			7186517	
		6	10-11/16			7186519	
	1-1/4	1-1/2	6-3/16	11/16	2-33/64	7186521	
		3-1/2	8-3/16			7186523	
		5-1/2	10-3/16			7186525	
	1-1/2	2-13/32	7-11/32	15/16	3-55/64	7186527	
		4	8-15/16			7186529	
		6	10-15/16			7186531	
	2	2-13/32	7-11/32	15/16	3-55/64	7186533	
		4	8-15/16			7186535	
		6	10-15/16			7186537	

## CATERPILLAR V-FLANGE JACOBS TAPER HOLDERS

**SERIES 658:**

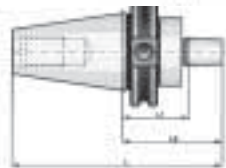

- Produced according to AT3 specifications.
- Made of alloy forged steel for long, durable service life.
- Hardened to RC 52-56 and ground to ensure maximum accuracy.
- Jacobs Taper T.I.R. < 0.0002".
- Retention Knobs are sold separately.

**Draw Bar Threads:**  
**CAT40** 5/8" - 11  
**CAT50** 1" - 8

Taper No.	Jacobs Taper	L	L <sub>1</sub>	L <sub>2</sub>	Order No.	Price
CT40	2	5.062		2.375	7181402	
	3	5.406		2.719	7181403	
	4	5.844	1.50	3.156	7181404	
	6	5.187		2.500	7181406	
CT50	33	5.187		2.500	7181433	
	3	6.718		2.719	7181503	
	4	7.157		3.156	7181504	
	5	7.375	1.50	3.375	7181505	
	6	6.500		2.500	7181506	
	33	6.500		2.500	7181533	

## CATERPILLAR V-FLANGE STUB ARBOR HOLDERS

**SERIES 659:**



- Shank taper accuracy AT3 or better.
- Made of alloy forged steel for long, durable service life.
- Hardened to RC 52-56 and ground to ensure maximum accuracy.
- Face is held perpendicular to centerline within 0.0002".
- Pilot diameter is sized for precision fit with cutter and is keyed for positive drive.
- Heavy duty locking RH nut and 5 arbor spacers are included - 1/16", 1/8", 1/4", 3/8", 3/4". For more spacers see page 549.
- Retention Knobs are sold separately.



**Draw Bar Threads:**  
**CAT-40** 5/8" - 11  
**CAT-50** 1" - 8

Taper No.	Arbor Dia. d	A	d <sub>1</sub>	L	B	Order No.	Price
40	1	4	1-1/2	7.0	2	7191410	
	1-1/4	4	1-3/4	7-1/4	2	7191415	
	1-1/2	4	2-1/8	7-1/2	2	7191420	
50	1	4	1-1/2	7.0	2	7191510	
	1	6	1-1/2	9.0	2	7191515	
	1-1/4	4	1-3/4	7-1/4	2	7191520	
	1-1/4	6	1-3/4	9-1/4	2	7191525	
	1-1/2	4	2-1/8	7-1/2	2	7191530	
	1-1/2	6	2-1/8	9-1/2	2	7191535	

## CATERPILLAR V-FLANGE SEMI FLUSH SLITTING SAW HOLDERS

**SERIES 659:**



- Shank taper accuracy AT3 or better.
- Made of alloy forged steel for long, durable service life.
- Hardened to RC 52-56 and ground to ensure maximum accuracy.
- Face is held perpendicular to centerline within 0.0002".
- Designed for slitting saws up to 5/16" thick. For wider cutters use Stub Arbor Holder.
- Pilot diameter is sized for precision fit with cutter and is keyed for positive drive.
- Semi-flush nose cap gets in tight areas.
- Retention Knobs are sold separately.

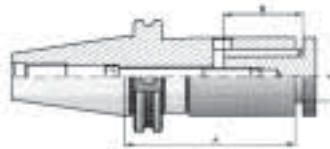

**Draw Bar Threads:**  
**CAT-40** 5/8" - 11  
**CAT-50** 1" - 8

Taper No.	Arbor Dia.	A	B	Order No.	Price
40	5/8	4	1.77	7192405	
	1	4	1.77	7192410	
	1-1/4	4	1.77	7192415	
50	1	4	1.77	7192510	
	1	6	3	7192515	
	1-1/4	4	1.77	7192520	
	1-1/4	6	3	7192525	

## BT FLANGE ER COLLET CHUCKS AND SETS

### SERIES 989:

- Suitable for use with all ER Collets.
- Produced to AT3 specifications.
- Collet seat taper T.I.R. < .0002".
- Alloy forged steel for long, durable service life.
- Hardened to RC 52-56 and ground to ensure maximum accuracy.
- Through spindle coolant capability.



### 17 pc. ER Collet Chuck Sets

Sets include 15 collets  
1/8-1x16<sup>m</sup>,  
collet chuck and  
wrench in case.



Draw Bar Threads:  
BT-40 M16 x 2  
BT-50 M24 x 3

Taper No.	Collet No.	Collet Range	L	D		Chuck Order No.	Price
BT 40	ER 25	3/64-5/8	2.36	1.65		7178425	
	ER 32	1/8-3/4	2.75	2.00		7178432	
	ER 40	1/8-1	2.75	2.50		7178442	
	ER 40	1/8-1	2.75	2.50	17 pc. Set	7178449	
BT 50	ER 32	1/8-3/4	2.75	2.00		7178532	
	ER 40	1/8-1	3.15	2.50		7178542	
	ER 40	1/8-1	3.15	2.50	17 pc. Set	7178549	
	ER 40	1/8-1	3.15	2.50			

See pages 584 - 587 for collets.

## BT EXTENSION TYPE COLLET CHUCKS

### SERIES 989:



Taper No.	Collet No.	Collet Range	L	L <sub>1</sub>	D	D <sub>1</sub>	Chuck Order No.	Price
BT 40	ER 16	1/32-25/64	3.94	-	1.10	-	7178414	
			5.91	3.35	1.10	1.57	7178416	
BT 50	ER 16	1/32-25/64	3.94	-	1.10	-	7178514	
			5.91	3.35	1.10	1.57	7178516	

## BT FLANGE JACOBS TAPER HOLDERS

### SERIES 991:

- Produced according to AT3 specifications.
- Made of alloy forged steel for long, durable service life.
- Hardened to RC 52-56 and ground to ensure maximum accuracy.
- Jacobs Taper T.I.R. < 0.0002".
- Retention Knobs are sold separately.



Taper No.	Jacobs Taper	L <sub>1</sub>	B	L	Order No.	Price
BT40	2	1-1/2	2.4	4.95	7175402	
	3		2.7	5.28	7175403	
	4		3.15	5.73	7175404	
	5		3.4	5.95	7175405	
	6		2.5	5.07	7175406	
	33		2.5	5.07	7175433	
BT50	3	2	3.2	7.2	7175503	
	4		3.65	7.6	7175504	
	5		3.85	7.83	7175505	
	6		3.0	7.0	7175506	
	33		3.0	7.0	7175533	

## BT FLANGE END MILL HOLDERS

### SERIES 988:



- Produced according to AT3 specifications.
- Made of alloy forged steel for long, durable service life.
- Hardened to RC 52-56 and ground to ensure maximum accuracy.
- End Mill Socket T.I.R. < 0.0002".
- Through spindle coolant capability.

Taper No.	d	L	D	C	B	Order No.	Price	
40	3/16	2.50	.78	.56	-	7179402		
	1/4	2.50	.78	.56	-	7179404		
	5/16	2.50	.87	.72	-	7179407		
	3/8	2.50	1.12	.75	-	7179411		
	3/8	4.00	1.12	.75	-	7179415		
	1/2	2.50	1.50	.88	-	7179421		
	1/2	4.00	1.50	.88	-	7179425		
	5/8	2.50	1.62	.94	-	7179431		
	5/8	4.00	1.62	.94	-	7179435		
	3/4	2.50	1.75	1.00	-	7179441		
	3/4	4.00	1.75	1.00	-	7179445		
	7/8	3.50	2.17	1.00	1.81	7179451		
	1	3.50	2.38	1.00	2.00	7179461		
	1	5.00	2.38	1.12	2.12	7179465		
	50	3/8	3.00	1.12	.75	-	7179511	
		1/2	3.00	1.50	.88	-	7179521	
5/8		3.00	1.62	.94	-	7179531		
3/4		3.00	1.75	1.00	-	7179541		
1		4.00	2.48	1.00	2.00	7179561		
1-1/4		4.00	2.69	1.00	2.00	7179571		
1-1/2		4.00	2.88	1.00	2.00	7179581		
2		5.00	3.62	1.38	2.88	7179591		

## BT FLANGE SHELL END MILL HOLDERS

### SERIES 990:

- Produced according to AT3 specifications.
- Made of alloy forged steel for long, durable service life.
- Hardened to RC 52-56 and ground to ensure maximum accuracy.
- Shell End Mill Pilot T.I.R. < 0.0002".
- Through spindle coolant capability.



Taper No.	d	D	L	L <sub>1</sub>	Order No.	Price
40	1/2	1.18	1-3/4	.56	7176403	
	3/4	1.50	2	.69	7176405	
	1	1.73	2	.69	7176407	
	1-1/4	2.08	2-1/4	.69	7176409	
	1-1/2	2.48	2-1/4	.92	7176411	
50	3/4	1.5	2-1/4	.69	7176509	
	1	1.73	2-1/4	.69	7176515	
	1	1.73	4	.69	7176517	
	1	1.73	6	.69	7176519	
	1-1/4	2.08	2-1/2	.69	7176521	
	1-1/4	2.08	4	.69	7176523	
	1-1/4	2.08	6	.69	7176525	
	1-1/2	2.48	2-1/2	.92	7176527	
	1-1/2	2.48	4	.92	7176529	
	1-1/2	2.48	6	.92	7176531	
2	2	3.07	2-1/2	.94	7176533	
	2	3.07	4	.94	7176535	

# RETENTION KNOBS

SERIES 378:

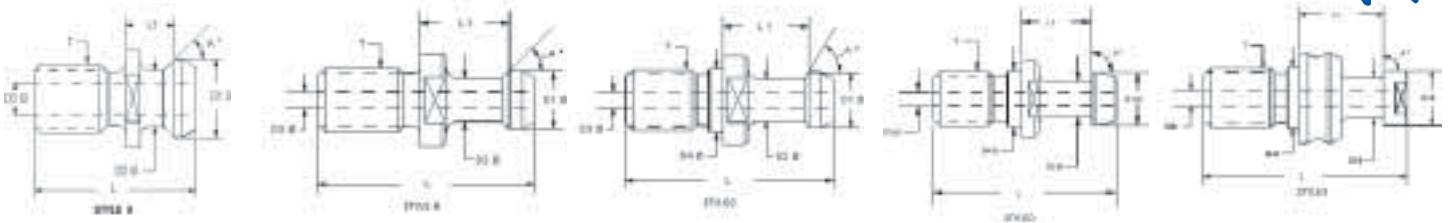

Order No.	Price	Style	"T" Threads Dia. Pitch	"A" Angle Radius	"D1" Knob Dia.	"D2" Neck Dia.	"D3" Hole Dia.	"D4" Pilot Dia.	"L" OAL In	"L1" Length In	Hole
			<b>TOOL</b>	<b>SHANK</b>	<b>BT-30</b>						
7831109		C	M12X1.75	45	0.431	0.2740	N/A	0.4918	1.690	0.707	N
8311091		C	M12X1.75	60	0.431	0.2740	N/A	0.4918	1.690	0.707	N
			<b>TOOL</b>	<b>SHANK</b>	<b>CT-30</b>						
7811111		A	.500-13	45	0.52	0.3850	0.187	N/A	1.100	0.320	Y
			<b>TOOL</b>	<b>SHANK</b>	<b>BT-40</b>						
8111221		A	M16X2.0	45	0.74	0.4900	0.281	N/A	1.500	0.440	Y
7811126		A	M16X2.0	45	0.74	0.4900	N/A	N/A	1.612	0.552	N
7831113		C	M16X2.0	45	0.589	0.3920	N/A	0.669	2.360	1.100	N
8311131		C	M16X2.0	60	0.589	0.3920	N/A	0.669	2.360	1.100	N
8311132		C	M16X2.0	90	0.589	0.3920	N/A	0.669	2.360	1.100	N
8311134		C	M16X2.0	45	0.589	0.3920	0.197	0.669	2.360	1.100	Y
8311135		C	M16X2.0	60	0.589	0.3920	0.197	0.669	2.360	1.100	Y
8311136		C	M16X2.0	90	0.589	0.3920	0.197	0.669	2.360	1.100	Y
			<b>TOOL</b>	<b>SHANK</b>	<b>CT-40</b>						
7811122		A	.625-11	45	0.74	0.4900	0.281	N/A	1.500	0.440	Y
7811123		A	.625-11	45	0.74	0.4900	N/A	N/A	1.500	0.440	N
7812622		B	.625-11	45	0.588	0.3920	N/A	N/A	2.265	1.000	N
7817122		B	.625-11	45	0.594	0.4060	N/A	N/A	2.250	1.139	N
7817123		B	.625-11	45	0.594	0.4060	0.157	N/A	2.250	1.138	Y
7831114		C	.625-11	45	0.589	0.3920	N/A	0.636	2.250	0.988	N
8311141		C	.625-11	60	0.589	0.3920	N/A	0.636	2.250	0.988	N
8311145		B	.625-11	60	0.589	0.3920	N/A	N/A	2.125	0.988	N
8311142		C	.625-11	90	0.589	0.3920	N/A	0.636	2.250	0.988	N
8311146		B	.625-11	90	0.589	0.3920	N/A	N/A	2.125	0.988	N
8311147		B	.625-11	45	0.589	0.3920	0.156	N/A	2.125	0.988	Y
8311148		B	.625-11	45	0.589	0.3920	N/A	N/A	2.125	0.988	N
7831222		D	.625-11	90	0.589	0.3880	N/A	0.625	2.037	0.777	N
7831226		A	.625-11	45	0.74	0.4900	0.280	0.6405	1.624	0.440	Y
7831514		C	.625-11	45	0.589	0.3920	0.200	0.636	2.250	0.988	Y
7831616		B	.625-11	15	0.746	0.5490	N/A	N/A	1.890	0.792	N
7831617		B	.625-11	15	0.746	0.5490	0.276	N/A	1.890	0.792	Y
8318141		C	.625-11	60	0.589	0.3920	0.138	0.636	2.250	0.988	Y
7832114		B	.625-11	45	0.588	0.3920	N/A	N/A	2.125	0.988	N
8324142		C	.625-11	90	0.589	0.3920	N/A	N/A	1.970	0.707	N
7835030		C	.625-11	90	0.589	0.3920	0.224	0.636	2.250	0.988	Y
			<b>TOOL</b>	<b>SHANK</b>	<b>CT45</b>						
7811133		A	.750-10	45	0.94	0.6050	0.375	N/A	1.800	0.580	Y
7831116		C	.750-10	45	0.746	0.5490	N/A	0.761	2.770	1.228	N
8311161		C	.750-10	60	0.746	0.5490	N/A	0.761	2.770	1.228	N
8311162		C	.750-10	90	0.746	0.5490	N/A	0.761	2.770	1.228	N
			<b>TOOL</b>	<b>SHANK</b>	<b>BT50</b>						
8111441		A	M24X3.0	45	1.14	0.8200	0.468	N/A	2.300	0.700	Y
7831117		C	M24X3.0	45	0.903	0.6680	N/A	0.9839	3.350	1.376	N
8311171		C	M24X3.0	60	0.903	0.6680	N/A	0.9839	3.350	1.376	N
8311172		C	M24X3.0	90	0.903	0.6680	N/A	0.9839	3.350	1.376	N
7831643		C	M24X3.0	45	0.903	0.6680	0.236	0.9839	3.350	1.376	Y
			<b>TOOL</b>	<b>SHANK</b>	<b>CT50</b>						
7811143		A	1.00-8	45	1.14	0.8200	0.505	N/A	2.300	0.700	Y
7811144		A	1.00-8	45	1.14	0.8200	0.468	N/A	2.300	0.700	Y
7811146		A	1.00-8	45	1.14	0.8200	N/A	N/A	2.300	0.700	N
7817144		A	1.00-8	45	1.14	0.8200	0.460	N/A	2.300	0.700	Y
7831118		C	1.00-8	45	0.903	0.6680	N/A	1.026	3.350	1.384	N
8311181		C	1.00-8	60	0.903	0.6680	N/A	1.026	3.350	1.384	N
8311185		B	1.00-8	60	0.903	0.6680	N/A	1.026	3.080	1.384	N
8311182		C	1.00-8	90	0.903	0.6680	N/A	1.026	3.350	1.384	N
8311186		B	1.00-8	90	0.903	0.6680	N/A	N/A	3.080	1.384	N
8311187		B	1.00-8	45	0.903	0.6680	0.390	N/A	3.080	1.384	Y
8311188		B	1.00-8	45	0.903	0.6680	N/A	N/A	3.080	1.384	N
8312441		E	1.00-8	90	0.908	0.6680	N/A	1.026	3.350	1.384	N
7831246		A	1.00-8	45	1.14	0.8200	0.390	1.026	2.300	0.700	Y
7831645		C	1.00-8	45	0.903	0.6680	0.390	1.026	3.355	1.384	Y
8318441		C	1.00-8	60	0.903	0.6680	0.335	1.026	3.355	1.384	Y
8324182		C	1.00-8	90	0.942	0.7060	N/A	N/A	2.519	0.904	N
8324202		A	1.00-8	90	0.942	0.7060	0.315	N/A	2.519	0.904	Y
8342182		C	1.00-8	90	0.903	0.6680	0.250	1.026	3.350	1.384	Y

## CNC TOOL CART HEAVY DUTY SERIES 451:

- Holds BT, CAT "V" Flange and NMTB tapers
- You can order the cart with your own "individual" selection of accessories or buy, proposed below, the most popular packages including:
  - Tool cart with handle.
  - Auxiliary work shelf.
  - 1 flat tray, 1 angled tray and 48 plastic tool protectors for #40 tapers or 40 protectors for #50 tapers.
- Your choice of #30, 40 or 50 taper plastic tool protectors.
- Carts are made of heavy gauge steel with red baked epoxy finish.
- Easy to push and maneuver.
- Plastic tool protectors hold tools securely in place.

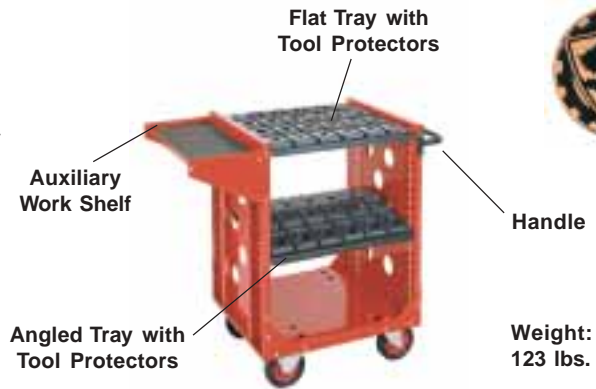

Description	Order No.	Price
Tool cart with Handle	7200002	
Auxiliary Work Shelf	7200021	
Flat Tray*	7200011	
Angled Tray*	9200012	
Plastic Tool Protectors for Taper #30	7200023	
for Taper #40	7200024	
for Taper #50	7200026	

Package No.	Description	Order No.	Price
#11	40 Taper	7200111	
#12	50 Taper	7200112	

Weight capacity: 1200 lbs.  
Dimensions: Height - 41"  
Length - 42"  
Width - 25"



Many other  
**CARTS & CONFIGURATIONS**  
available; please inquire.

\* Holds 6 - Taper #30 or Taper #40 plastic tool protectors, or 5 - Taper #50 plastic tool protectors.

## CNC TOOL CART SERIES 569:



2-Storage trays, protective lining inside. Angled tray for easy, quick tool access from either side. Heavy duty 5" x 1-1/4" casters load rated at 1000 lbs. Heavy gauge - all steel infrared/baked epoxy finish. Solid side panels for maximum strength & stability. Interlocking side panel construction adds strength. Durable nylon inserts to help prevent damage.



Model No.	Order No.	Taper	Description	Price
13930	9913930	#30	Holds 48 BT, CAT V Flange, NMTB	
13935	9913935	#35	Holds 48 BT	
13940	9913940	#40	Holds 48 BT, CAT V Flange, NMTB	
13945	9913945	#45	Holds 36 BT, CAT V Flange	
13950	9013950	#50	Holds 36 BT, CAT V Flange, NMTB	

Weight: 75 lbs.  
Dimensions: 18"W x 35-1/4"L x 35"H

## CNC TOOLHOLDER RACK FOR 40 & 50 TAPERS

### SERIES 569:

Bench mount, hand carry, or mount on top of your shop cart to move your 40 & 50 taper tools to the job. Made of heavy gauge steel with nylon inserts to help protect your tooling, painted texture black with Huot's pollution free powder coating process. Built-in end handles for comfortable carrying.



Model No.	Order No.	Description	Price
14780	14780	For 40 taper tools, holds 6 tools	
14790	14790	For 50 taper tools, holds 5 tools	

## CNC TOOL TOWER SERIES 569:

- Provides economical, free standing storage for 30, 40, 50 taper tools.
- The Tool Tower comes with 3 shelves and can be stacked to form a 5 or 6 shelf tower (optional stacking kit sold separately).
  - Nylon inserts protect each holder.
  - Sturdy 16 gauge steel construction.



Weight: 65 lbs.  
Dimensions: 27-5/16" W x 18-5/16" D x 36" H

Model No.	Description	Taper	Order No.	Price
13830	Holds 24 tools	30	5613830	
13840	Holds 24 tools	40	5613840	
13850	Holds 18 tools	50	5613850	
14860	Stacking Kit	-	5613860	