

MACHINE MOUNTS

SERIES 450:



Effectively Isolate Vibration In Two Ways:

1. By preventing a vibrating machine from transferring vibration to other machines.
2. By insulating precision machinery from external sources of vibration.

- Royal Machine Mounts meet OSHA requirements by preventing machines from "walking" - without the need for bolting or cementing.
- All mounts incorporate a large, chloroprene rubber base which is resistant to oil, water, and many chemicals.
- All metal parts are zinc plated for rust protection and long life.
- Support cup is machined from a solid bar instead of deep drawn, resulting in increased thickness and longer life.
- Unique retaining clip ensures that mounts will stay together when machine is moved to a new location.
- Better machine performance and reduced maintenance costs are two of the many benefits of using Royal Machine Mounts.



Choosing the Correct Royal Machine Mounts. Calculate the load on each mount by dividing the total weight of the machine by the number of mounting locations. Note: sometimes it may be necessary to compensate for machines which do not have an evenly distributed load.

Type	1	2	3	4	5
Order No.	27001	27002	27003	27004	27005
Load Range per Mount (lbs.) General Non-Impact Machinery	100-1,100	880-2,200	1,760-5,500	3,300-8,800	6,600-12,000
Load Range per Mount (lbs.) Presses					
125 strokes/min-max	150-440	440-880	880-3,080	3080-5,940	5,940-8,800
180 strokes/min-max	130-300	260-770	770-2,420	2420-4,290	4,290-7,700
200 strokes/min-max	110-260	260-550	550-1,760	1760-2,860	2,860-5,280
Max. Load per Mount (lbs.) Plastic Injection Molding Machines	390	790	2,180	5,450	8,220
Diameter	3-5/32"	4-3/4"	6-5/16"	6-5/16"	7-7/8"
Height, Including Leveling Plate	1-5/8"	1-15/16"	2-5/16"	2-5/16"	2-23/32"
Over-All Height	5-1/4"	5-1/4"	7-1/2"	7-1/2"	7-7/8"
Level Adjustment	23/32"	23/32"	1"	1"	1"
Leveling Bolt Size	M12x1.25	M16x1.5	M20x1.5	M20x1.5	M20x1.5
Standard Leveling Bolt Length	4-23/32"	4-23/32"	6-11/16"	6-11/16"	6-11/16"
Price Each					

Stainless steel and zinc plated mounts available; please inquire.

MACHINIST JACK

SERIES 508:



- Base is made of heavy cast steel.
- Adjustable screw and tilting swivel head.
- Range: 3-4"/75-100mm
- Approximately 1"/25mm adjustment
- 1000 lb. lifting capacity.
- For use on various machine tools or wherever leveling is necessary.

Order No.: 5080001

Price:



HEAVY DUTY SET INCLUDES:

- Jack, extension bases & attachments.
- Range: 2-1/4 - 3-3/8"mm / 75-100mm

Order No.: 5080150

Price:

"LITTLE GIANT" JACK SCREWS

STARRETT SERIES 190, 191:



For leveling work on planer beds, upright drills and setting up machinery. The versatility of this tool is greatly increased by the number of attachments available.



- Ability to lift 1,000 lbs. or more.
- 20-pitch screws for fine adjustments.
- Can be used on uneven and round surfaces.

Catalog No.	EDP Order No.	Description	Price
Range 2-1/4" - 3-3/8"			
S190	50680	Set Complete with all Attachments	
Range 1-1/2" - 2-1/4"			
S191	50687	Set Complete with all Attachments	

ARBOR PRESSES SERIES 422:

- Heavy duty construction
- Precision made
- 4-way anvils



MEGA
Superior Import

Ratcheting
Type

PANAPRESS SERIES 345:



Model 502

Ideal for pressing bearings, sleeves, collars, forming and assembling small parts, broaching, staking, etc.

- Reversible ram is 0.75" x 0.75" (19.1mm x 19.1mm) and 5.875" (149.2mm) long and applies up to 1/4 ton (500 lbs/227 kg) of pressure!

- One end of the ram is pre-drilled for adding tooling
- Four adjustable nylon gibs provide exceptional ram control
- Arm is 8" (203.2mm) long.
- Base footprint is 3.7" (94 mm) x 7" (177.8mm) and includes four 0.25" (6.3mm) holes countersunk at the corners for bolting to a work surface.
- Height (from base to top of back-not including variable ram height or arm length): 7" (177.8mm).
- Weight: 5.4 lbs. (2.5 Kg).

Order No. **3450502**

Price:



Model No.	Tons Pressure	Height Over Table	Height of Press	Base Size	Leverage Ratio	Wt.	Order No.	Price
0	1/2	4-1/2	10	4 x 9-1/2	20:1	25 lbs.	2405000	
1	1	5-1/2	13	5 x 11	25:1	40 lbs.	2405001	
2	2	8-1/2	18	6-3/4 x 17	35:1	88 lbs.	2405002	
3	3	12-1/2	23	8 x 18	50:1	160 lbs.	2405003	
5	5	18	35	10 x 26-3/4	50:1	325 lbs.	2405005	
Ratcheting Type - For Heavier Applications								
3R	3	12-5/8	21-1/2	8 x 18	-	178 lbs.	2401013	
5R	5	18-1/4	34-1/2	11.5 x 26.5	-	380 lbs.	2401015	

PHASE-A-MATIC PHASE CONVERTERS SERIES 222:

SERIES 222:

Runs three-phase equipment on existing 220V single-phase power

For long heavy starting loads, instant reversing, momentarily overloaded motors, or imported equipment; please inquire. Voltage stabilizer available for high line voltage and voltage-sensitive equipment such as CNC's; please inquire.



STATIC CONVERTERS

(Runs motor loads only at 2/3 rated HP)

How to Size:

The largest motor on your machine must fall within the minimum and maximum range of the converter. Do not order a larger unit or heavy duty model thinking it will give you more horsepower.

When To Use Heavy Duty:

Heavy starting loads (lathes, flywheel driven equip., etc.). Instant reversing, frequent starting, jogging. Air compressors (motor pulley must be reduced by 1/3 diameter).

Heavily Loaded Equipment:

Pumps, fans, blowers, direct-drive compressors, or equipment requiring greater than 2/3 of its rated HP, use a **PHASE-A-MATIC** rotary converter listed below.



For Light to Moderate Loads

Regular Duty Series			
Model No.	Order No.	H.P. Range	Price
PAM-100	2220100	1/3 TO 3/4	
PAM-200	2220200	3/4 TO 1-1/2	
PAM-300	2220300	1 TO 3	
PAM-600	2220600	3 TO 5	
PAM-900	2220900	4 TO 8	
Heavy Duty Series			
PAM-100HD	2221100	1/3 TO 3/4	
PAM-200HD	2221200	3/4 TO 1-1/2	
PAM-300HD	2221300	1 TO 3	
PAM-600HD	2221600	3 TO 5	
PAM-900HD	2221900	4 TO 8	
PAM-1200HD	2221200	8 TO 12	
PAM-1800HD	2221800	12 TO 18	
PAM-3600HD	22213600	20 TO 30	
PAM-5000HD	22215000	30 TO 50	

ROTARY CONVERTERS

(For running motor loads greater than 2/3 rated HP)

FEATURES:

- Multi-motor operation
- Multi-speed applications
- Resistive load applications
- No changing motors or switch gear
- Full 12 month warranty
- Easy to install
- No interference to TV, etc.

For larger sizes or 460V operation, please inquire.

Heavy Load Applications



Model No.	Order No.	H.P. Range	Price
R-1	2222001	1	
R-2	2222002	2	
R-3	2222003	3	
R-5	2222005	5	
R-7	2222007	7-1/2	
R-10	2222010	10	
R-15	2222015	15	
R-20	2222020	20	
R-30	2222030	30	
R-40	2222040	40	
R-50	2222050	50	
R-60*	2222060	60	
R-80*	2222080	80	
R-100*	2222100	100	

*Multiple Unit Model



PEDESTAL ROLLER



Super Duty Roller Stands - Feature an exclusive wedge shaped upper support column that actually becomes tighter under load. A quick twist handle locks the column firmly in position while the large ball bearing roller offers superior performance with even the heaviest stock. HSS-18 is perfect for drill presses vertical band saws and higher tools.

22" - 32" vertical height adjustment

Order No. 5081515 HSS-15

Price:

28" - 45-1/2" vertical height adjustment

Order No. 5081518 HSS-18

Price:

VEE ROLLER

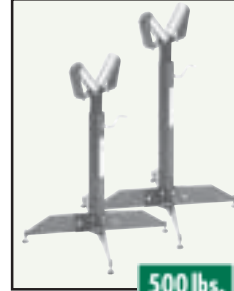

Designed for use in supporting and moving tubing, solids and pipe. Features 500 lb. capacity. Height range: HSV-15, 22" x 32"/ HSV-18, 26-1/2" x 43-1/2". Vee Roller features tough powder coated finish, heavy-duty galvanized steel rollers with ball bearings at both roller ends and four rubber non-slip leveling glides.

Order No. 5083515 HSV-15

Price:

Order No. 5083518 HSV-18

Price:



ROLLER TABLES

These patented roller tables have 5 rollers. HRT-15 has work height range of 22" to 32". HRT-18 range from 26-1/2" - 43-1/2". Exclusive wedge-shaped designed leg tightens under load conditions and prevents slipping.

Width: 15"

Length: 18"

Order No. 5082515 HRT-8

Price:

Order No. 5082518 HRT-10

Price:

ROLLER TABLES



Built to last. They feature durable, adjustable wedge-shaped support legs. Handles loads up to 500 lbs. All rollers are galvanized steel ball bearing. All twin leg models fold-up for easy storage. Heights can be adjusted from 26-1/2" - 43-1/2".

Width	Length	# Rollers	Order No.	Price
15"	66"	9	5086800	
15"	66"	17	5087000	
24"	66"	9	5088800	
24"	66"	17	5089000	

TOOL TABLES



Patented tool tables are constructed of heavy gauge steel. A 13.5" x 23.5" x 1" MDF top and sturdy four-corner bracing systems allows 500 lbs. of support. Lower braces are pre-drilled for an auxiliary shelf (plans included) and feature adjustable rubber-tipped feet. Available in (HBT-320) 20" or (HBT-330) 30" heights to meet your workshop needs.

Order No. 5083320 HBT-320

Price:

Order No. 5083330 HBT-330

Price:

TOOL SAVERS



TS-9036 Small (27" x 36")

TS-9056 Medium (36" x 56")

TS-9072 Large (56" x 72")

TS-9112 Jumbo (72" x 112")

"Breathable" Tool-Saver protects your tools from performance threatening condensation and rust. These unique covers are made of rugged cotton sheeting that's scientifically skip-coated with plastisol, then perforated with thousands of microscopic holes that allow it to breathe, yet remain water-resistant. Stays in place with a double-needle roll-hem and rubberized magnets in each corner.

Order No.	Size	Price
5089036	Small	
5089056	Medium	
5089072	Large	
5089112	Jumbo	

TOOL-GRINDER PEDESTALS



Constructed with thick-walled square steel tubing and feature unique wedge-shaped inner support column that eliminates slipping. Columns can be adjusted vertically from 22" to 45". 3 different table sizes. Adjustable 4-point leg system improves stability.

Top: 8-1/2 x 9-1/2"

Order No. 5081208 HGP-10

Price:

Top: 17" x 20"

Order No. 5081212 HGP-12

Price:

DRILL PRESS ACCESSORY



Allows for safer and easier work with large and heavy work pieces. Easily attaches to any drill press with a 2-1/2" to 4" diameter column. Features two adjustable supports that extend to 28" on both sides of your machine's center line. Provides a stable 56" wide work surface. Includes galvanized steel ball bearing rollers and 3" x 10" accessory tray for holding drill bits, chuck key, etc.

Order No. 5080128

Price:

RIGHT ANGLE ATTACHMENT SET

FOR BRIDGEPORT® TYPE MACHINES

SERIES 508:



DORIAN TOOL



Individual components may be purchased separately; please inquire.

Tooling sold separately.

RIGHT ANGLE ATTACHMENT FEATURES

- Ductile Iron Body
- Grease Fitting
- Precision Hardened & Ground Spiral Bevel Gears
- R-8 Collet Spindle
- Sealed High Speed Bearings
- 1.33 to 1 Gear Ratio
- Alignment Flats on 2 Sides

ARBOR SUPPORT FEATURES

- Quick Lock System
- Quick Center Line Adjustment
- Double Dovetail Track
- Precision Needle Bearing
- Overarm Adjustment
- Steel Support
- Aluminum Body

Order No.	Price	4 pc. Set Includes:
6104076*		1 Right Angle Attachment 1 Arbor Support 1 R8 Arbor 1 Drawbar

*Please specify machine type when ordering.

SPEEDY POWER DRAWBAR

SERIES 508:

For Variable and Step Pulley Type Milling Machines



- Four Second Tool Change
- Easy Installation and Operation, No Special Tools Needed.
- Push Button Control
- Uses Standard Shop Air Supply
- Eliminates Excessive Downtime
- Increases Productivity
- Ends Collet Sticking
- Provides Uniform Tightening of Collets
- Limited Warranty

Standard R8 Variable Speed

Order No. 0801038

Price:

Standard R8 Step Pulley

Order No. 0811038

Price:



POWERLOCK™ POWER DRAWBARS

AUTOMATIC AND MECHANICAL POWERLOCK DRAWBARS

Also available; please inquire.

TWO-LIFE DRAWBARS

SERIES 508:

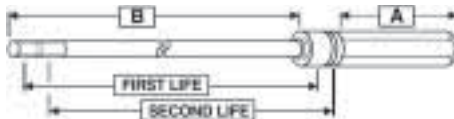

- Two drawbars in one
- Prevents excessive downtime
- Longer hex head & extended thread length
- To obtain "second life" after the end wears out, cut off at "V" notch and remove large spacer

Order No.	Dim. "A"	Dim. "B"	Thread Size	Type of Milling Mach.	Price
5081026	4-1/4	18-1/4	R8 7/16-20	Variable Speed	
5081028	1-1/2	18-1/4	R8 7/16-20	Step Pulley	

QUILL FEED HANDLE

SERIES 508:



Replaces conventional handle for speeding up operations on Bridgeport® type machines.

Order No. 2585001

Price:



QUILL STOP

SERIES 508:



- Quick acting clip easily attaches to quill of Bridgeport® or similar type machines for rapid depth setting.
- Top or bottom positioning
- Easily removable

Order No. 2585003

Price:



MACHINE SET-UP GAGE

SERIES 508:



NEW IMPROVED MODEL

- Easily center cutting tools for cut off, taper turning, and various other operations.
- Index many common jobs rapidly without expensive and slow dividing equipment.
- Comes with complete instructions.
- Easy to read vial.

Order No. 5080002

Price:

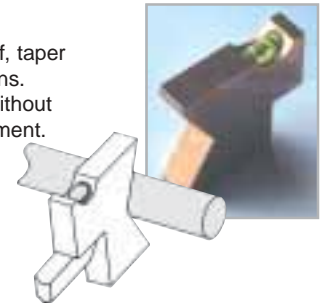

CLOCK SPRING ASSEMBLY

FOR MOST BRIDGEPORT® TYPE MACHINES

SERIES 508:



Order No. 5081112

Price:



HAND SHEAR MACHINES

SERIES 508:



- Lever type
- Ideal machine for shearing sheet, steel, bars and rods.
- Hardened and tempered replaceable blades.
- Long handles provides plenty of shearing torque.
- Comes with predrilled holes to bolt down to work bench.



Order No.	Blade Length	Weight	Price
5086001	6"/150mm	26lbs/12kg	
5086002	8"/200mm	40lbs/19kg	
5086003	10"/250mm	48lbs/22kg	
5086004	12"/300mm	54lbs/24kg	